

Котломоечные машины WD

Технические характеристики

По вопросам продаж и поддержки обращайтесь:

Алматы (727)345-47-04
Ангарск (3955)60-70-56
Архангельск (8182)63-90-72
Астрахань (8512)99-46-04
Барнаул (3852)73-04-60
Белгород (4722)40-23-64
Благовещенск (4162)22-76-07
Брянск (4832)59-03-52
Владивосток (423)249-28-31
Владикавказ (8672)28-90-48
Владимир (4922)49-43-18
Волгоград (844)278-03-48
Вологда (8172)26-41-59
Воронеж (473)204-51-73
Екатеринбург (343)384-55-89

Иваново (4932)77-34-06
Ижевск (3412)26-03-58
Иркутск (395)279-98-46
Казань (843)206-01-48
Калининград (4012)72-03-81
Калуга (4842)92-23-67
Кемерово (3842)65-04-62
Киров (8332)68-02-04
Коломна (4966)23-41-49
Кострома (4942)77-07-48
Краснодар (861)203-40-90
Красноярск (391)204-63-61
Курск (4712)77-13-04
Курган (3522)50-90-47
Липецк (4742)52-20-81

Магнитогорск (3519)55-03-13
Москва (495)268-04-70
Мурманск (8152)59-64-93
Набережные Челны (8552)20-53-41
Нижний Новгород (831)429-08-12
Новокузнецк (3843)20-46-81
Ноябрьск (3496)41-32-12
Новосибирск (383)227-86-73
Омск (3812)21-46-40
Орел (4862)44-53-42
Оренбург (3532)37-68-04
Пенза (8412)22-31-16
Петрозаводск (8142)55-98-37
Псков (8112)59-10-37
Пермь (342)205-81-47

Ростов-на-Дону (863)308-18-15
Рязань (4912)46-61-64
Самара (846)206-03-16
Санкт-Петербург (812)309-46-40
Саратов (845)249-38-78
Севастополь (8692)22-31-93
Саранск (8342)22-96-24
Симферополь (3652)67-13-56
Смоленск (4812)29-41-54
Сочи (862)225-72-31
Ставрополь (8652)20-65-13
Сургут (3462)77-98-35
Сыктывкар (8212)25-95-17
Тамбов (4752)50-40-97
Тверь (4822)63-31-35

Тольятти (8482)63-91-07
Томск (3822)98-41-53
Тула (4872)33-79-87
Тюмень (3452)66-21-18
Ульяновск (8422)24-23-59
Улан-Удэ (3012)59-97-51
Уфа (347)229-48-12
Хабаровск (4212)92-98-04
Чебоксары (8352)28-53-07
Челябинск (351)202-03-61
Череповец (8202)49-02-64
Чита (3022)38-34-83
Якутск (4112)23-90-97
Ярославль (4852)69-52-93

Россия +7(495)268-04-70

Казахстан +7(727)345-47-04

Беларусь +(375)257-127-884

Узбекистан +998(71)205-18-59

Киргизия +996(312)96-26-47

эл.почта: wkd@nt-rt.ru || сайт: <https://wexiodisk.nt-rt.ru/>

HOOD TYPE DISHWASHER

FEATURES

- Unique and flexible washing system. The machines water pressure can be reset quickly and easily between normal and heavily soiled settings
- Robust and reliable design in stainless steel with components that guarantee a durable and reliable operation for many years
- The machine has an energy saving heat and sound insulating double-skinned hood
- A good working environment with the unique hood concept
- High levels of hygiene with an automatic cleaning programme and guaranteed rinse temperature by thermal stop system
- Self-drained wash pump
- Large deep tank to protect against foaming
- Easy servicing - the machine is serviced from the front
- Hygiene control – control system with integrated HACCP
- Excellent wash results – with selfdraining washing arms
- Powerful washing pressure with anti-blocking nozzles
- Individual adjustable wash- and rinse times as well as temperatures for each programme
- Inbuilt dosing pump for fine dosage of rinse aid
- Automatic cleaning program



OPTIONS

- Automatic hood
- Autostart for automatic hood (not in combination with foldable shelf)
- 230V/3/50Hz
- Detergent pump for liquid detergent
- Booster heater for cold water connection
- Foldable shelf
- Booster pump connected with WD-PRM7 equipped with automatic hood (In combination with break tank)
- ECO-FLOW condensing unit with heat recovery (cold water connection is required)
- Drain pump
- Separate filling of tank
- Break tank with booster pump (to be used when no external resuction protection is mounted)
- WEB Tool - For external HACCP documentation

EXTRA EQUIPMENT

- Shelf for chemical storage
- Sideboard (560 x 560 mm)
- Rack for 8 pcs baking plates
- Special rack for containers

TECHNICAL DATA	WD-8
Wash pump (kW)	1.5
Booster heater (kW)	9/12*
Tank heater (kW)	1.8
Booster pump (kW)**	0.6**
Drain pump (kW)**	0.04**
Tank volume (litres)	50
Weight, machine in operation (kg)	170
Enclosure class (IP)	45

- * 12 kW booster heater is optional.
 ** Optional.

CAPACITY AND OPERATING DATA	WD-8
Total washing time P1 (min)	1.2**
Total washing time P2 (min)	1.7**
Total washing time P3 (min)	3.2**
Max. capacity, baskets/hour (no.)	50
Water consumption rinsing/programme (litres)	2.5-4***
Energy consumption (% of connected power)	70-90%
Sound level (dB(A))*	62/60

- * Measured 1 metre from the side of the machine.
 ** Factory setting. The washing time can be adjusted.
 *** The water consumption depends on local conditions. An exact adjustment is made during installation.

CONNECTION, MACHINE	WD-8
Total connected power (kW)	10.5/13.5*
Main fuse 400V 3N~ (A) **	16/25*
Max. connection area 400-415V 3N~ (L1-L3,N,PE) Cu (mm2) ***	2.5

- * With 12 kW booster heater (optional).
 ** Other voltage on request.
 *** Cable 3 m H07RN-F is included.

WATER, DRAIN AND VENTILATION CONNECTIONS	WD-8
Water quality, hardness (°dH)	2 - 7
Water connection 5-65°C (external thread)*	R 1/2"
Drain connection, PP pipe (ø mm.)	50
Water capacity, min/max pressure (kPa)	180**
Water capacity, flow (litres/min)	18
Water capacity hood lift, pressure (kPa)	300**
Floor drain, capacity (litres/sec)	3
Heat load to the room (total, sensible, latent) (kW)	2.3 / 1.7 / 0.6
For machines with the option ECO-FLOW: heat load to the room (total, sensible, latent) (kW)	1.2 / 0.9 / 0.3

* If colder water than 55°C a 12 kW booster heater is recommended.

** If pressure/flow is lower the machine should be equipped with a break tank.

SIZE AND WEIGHT FOR TRANSPORTATION	WD-8
Size, LxWxH (mm.) *	765x880x1650
Weight (kg) *	135

* Packaging included

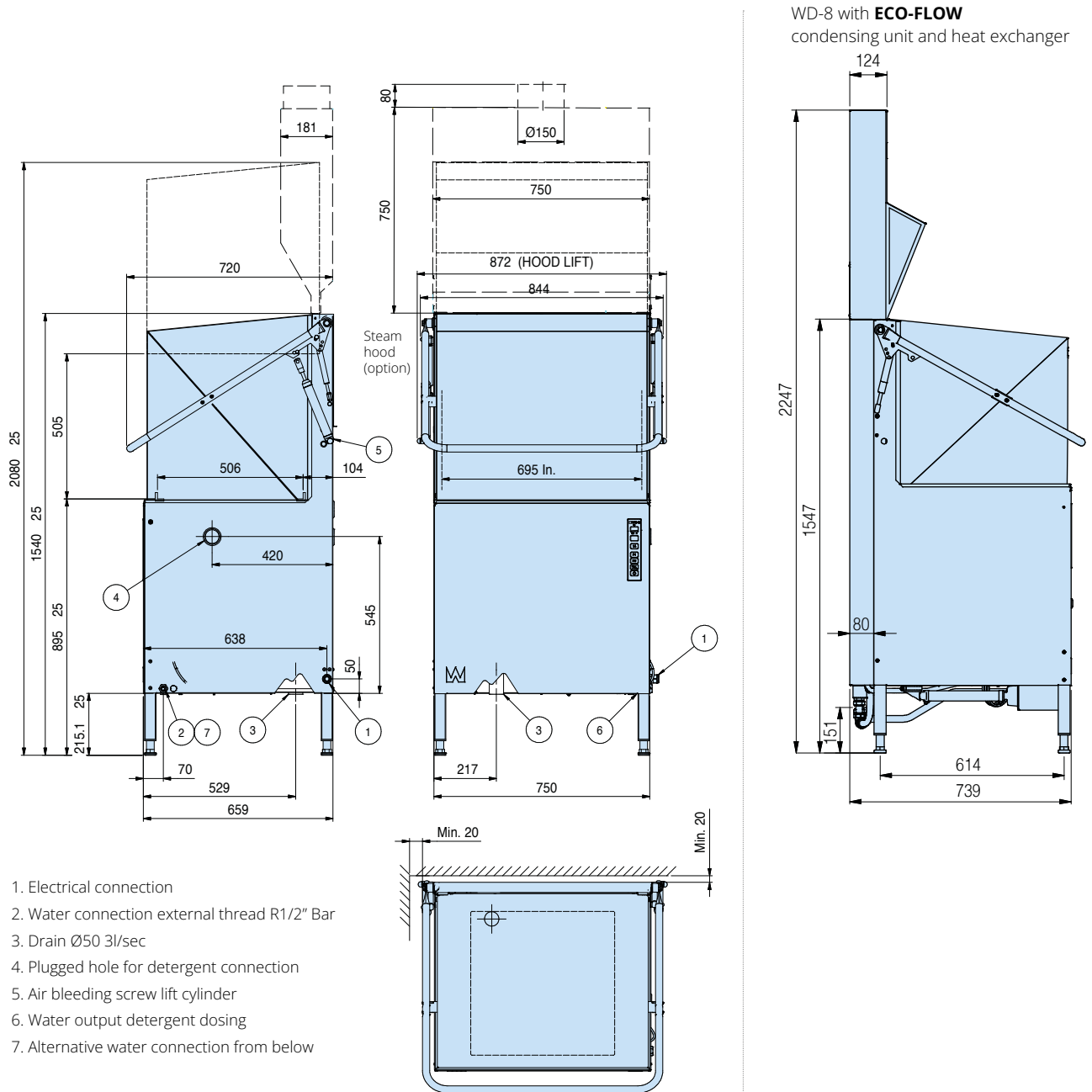

We reserve the right to change technical data.



WD-10S

POT / COMBI DISHWASHER

FEATURES

- Versatile pot dishwasher with a dual-pump system that operates at high pressure and flow rates to clean dishes without using granules.
- Suitable for heavy-duty dishwashing in schools, bakeries, food catering facilities, stores, etc.
- Loading dishes through the door provides a compact installation and ergonomic handling of dishes.
- Capable of accommodating bulky dishware with an opening height of 820 mm.
- Powerful dishwashing with water pressure of up to 1 bar.
- Electrically controlled water pressure allows easy adjustment for regular dishwashing.
- Offers options for varied heavy-duty dishwashing tasks.
- 4 different washing programs available.
- Low noise level relative to dishwashing power.
- Dosing pump for fine dosage of rinse aid.
- Soft start feature.
- Soaking program with reduced water pressure.
- Easy to clean with smooth interior surfaces.
- Display in tempered glass.
- Drain pump with functions such as automatic draining and water change.
- Break tank with boosting pump according to EN1717 standards.
- Energy-saving system
- Compact installation
- Status indication
- Energy-saving mode
- New spray arm - optimized for better coverage and designed for heavy-duty dishwashing.
- Customized basket inserts for different types of dishware.
- Interior lighting



OPTIONS

- ECO-FLOW heat recovery with rinse function.
- Stainless steel fittings in final rinse.
- Detergent dosing for liquid detergents.
- Lowered lift height 130 mm for adaption to limited ceiling height.

TECHNICAL DATA	WD-10S
Washing pump potwashing (kW)	2.35
Washing pump normal wash (kW)	0.75
Booster heater (kW)	12
Tank heater (kW)	9
Booster pump (kW)	0.58
Drain pump (kW)	0.1
ECO-FLOW heat recovery (W)*	52
Tank volume (liter)	90
Weight, machine in operation (kg)	370
Enclosure class (IP)	45

* Option

CAPACITY AND OPERATING DATA	WD-10S
Total washing time P1 (min) *	2.0
Total washing time P2 (min) *	3.7
Total washing time P3 (min) *	6.0
Soaking program (min)*	15
Basket size (mm)	815x670
Max. capacity, baskets/hour (no.)****	30
Water consumption rinsing/programme (liter) **	4
Noise level (dB(A))*** Normal/Heavily	53/56

* Factory setting. The washing time can be adjusted.

** The water consumption depends on local conditions. Fine adjustments can be made during installation.

*** SS-EN ISO 9614-2 The A-weighted sound pressure level LpA in a free field 1 meter from the machine.

**** If colder water than 50°C, the capacity is reduced.

CONNECTION, MACHINE	WD-10S
Total connected power (kW)	14.4
Main fuse 400-415V 3N~ (A)*	25
Max. connection area 400-415V 3N~ (L1-L3,N,PE) Cu (mm2)**	4

* Other voltage on request.

** Cable 3 m is included.

WATER, DRAIN AND VENTILATION CONNECTIONS	WD-10S
Water quality, hardness (°dH)	2 - 7
Warm water connection 50-65°C (external thread)	G¾
Drain connection, PP pipe (ø mm.)	22
Water capacity, pressure (kPa)	100-600
Water capacity, flow (litres/min)	5
Floor drain, capacity (litres/sec)	3
Heat load to the room (total, sensible, latent) (kW)	3.9 / 2.9 / 1.0
For machines with the option ECO-FLOW: heat load to the room (total, sensible, latent) (kW)	2.7 / 2.0 / 0.7

SIZE AND WEIGHT FOR TRANSPORTATION	WD-10S
Size, LxWxH (mm.)*	1035x1035x2005
Weight (kg)*	277

* Packaging included

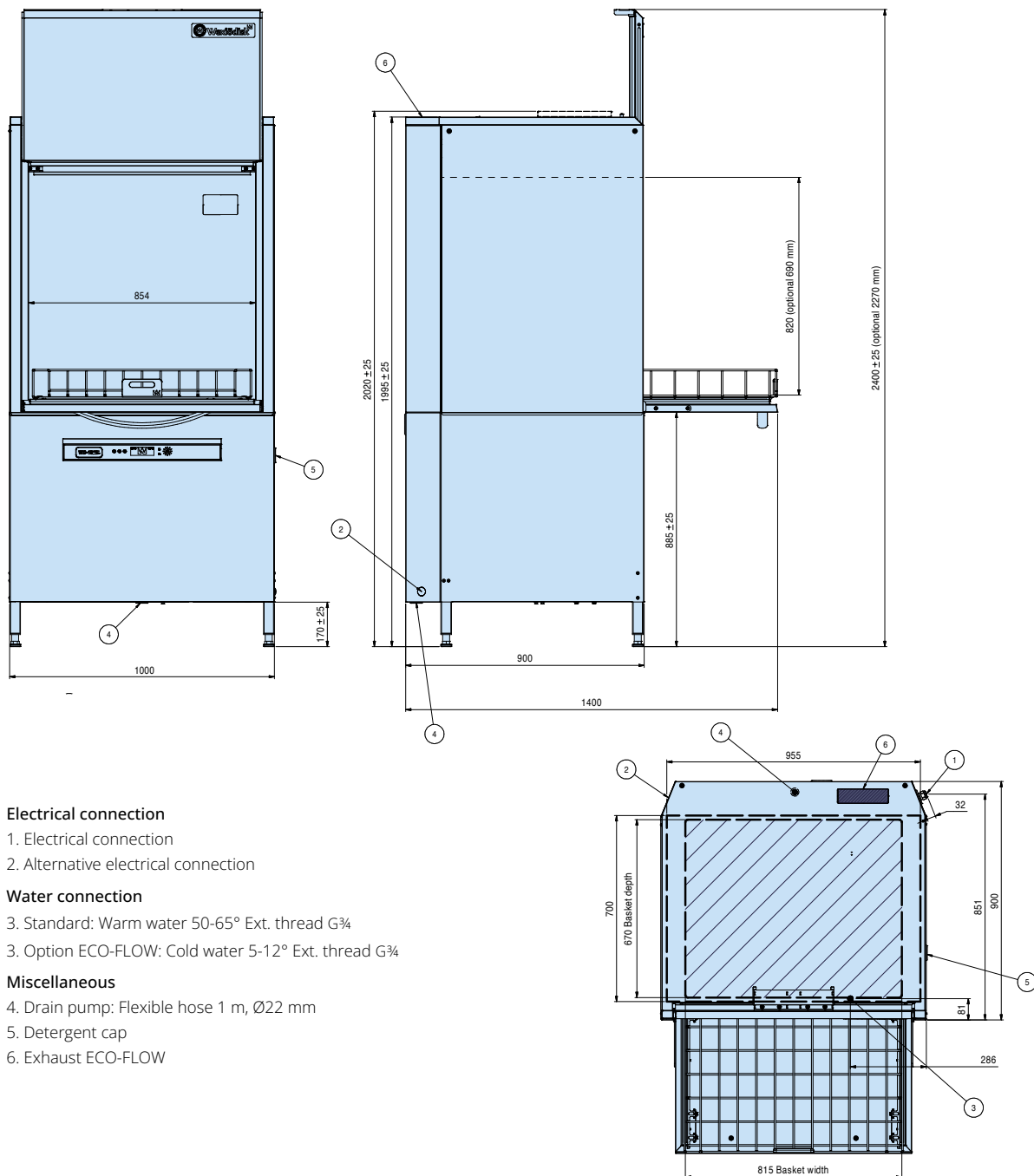

Electrical connection

1. Electrical connection
2. Alternative electrical connection

Water connection

3. Standard: Warm water 50-65° Ext. thread G¾
3. Option ECO-FLOW: Cold water 5-12° Ext. thread G¾

Miscellaneous

4. Drain pump: Flexible hose 1 m, Ø22 mm
5. Detergent cap
6. Exhaust ECO-FLOW

We reserve the right to change technical data.



WD-12S

COMBI-DISHWASHER

FEATURES

- Very flexible combi-dishwasher with a large washing compartment for baskets 500x500 as well as other bulky items.
- The machine has adjustable water pressure for normal and/or potwashing.
- Powerful and effective – extraordinary washing results with dual pumps and rinsing system.
- Angled ceiling improves the washing result and the steam is evacuated behind the machine and not in the face of the user. No water is dripping on the clean dishes.
- Good hygiene with smooth interior surfaces and rounded corners, foldable basket conveyor and only one strainer to clean.
- Automatic cleaning program and guaranteed final rinse temperature.
- The machine has an energy saving heat and sound insulating double-skinned hood.
- Automatic hood lift as standard.
- Self-drained wash pump.
- Large deep tank to protect against foaming.
- Hygiene control – control system with integrated HACCP.
- Excellent washing results - with selfdraining wash arms and concave washing and rinsing nozzles which prevents clogging.
- Individual adjustable wash- and rinse times as well as temperatures for each programme.
- Dosing pump for fine dosage of rinse aid.
- Break tank with booster pump according to EN1717.



- Easy servicing - the machine is serviced from the front.
- Robust and reliable design in stainless steel with components that guarantee a durable and reliable operation for many years.

OPTIONS

- ECO-FLOW with "fast fill" and auto cleaning function. Condensing unit with heat recovery by the exhausted steam (cold and warm water connection required)
- 230V/3/50Hz
- Basket conveyor with integrated grids
- Autostart
- Detergent dosage for liquid detergent
- Drain pump
- 15 kW cold water connection
- Adapted for WD-PRM7
- Lowered lift height 50 or 100 for adaptation to limited ceiling height
- Connection power restriction
- Demiwater rinse with dual water connections
- Stainless couplings in the final rinse
- Panel on left side
- Marine version
- WEB Tool - For external HACCP documentation
- Stainless steel basket 1090x500 mm

TECHNICAL DATA	WD-12S
Washing pump (kW)	2x1.5
Booster heater (kW)	12
Booster heater (machine with cold water connection) (kW)*	15
Booster heater (condensing unit) kW*	15 (12 selectable)
Tank heater (kW)	9
Booster pump (kW)	0.58
Drain pump (kW)*	0.17
Tank volume (liter)	100
Weight, machine in operation (kg)	385
Enclosure class (IP)	45

* Option

CAPACITY AND OPERATING DATA	WD-12S
Total washing time P1 (min) *	1.2
Total washing time P2 (min) *	1.7
Total washing time P3 (min) *	5.2
Max. capacity, baskets/hour (no.)	100
Water consumption rinsing/programme (liter) **	5.5 - 8
Noise level (dB(A))*** Normal/Heavily	64/63

* Factory setting. The washing time can be adjusted.

** The water consumption depends on local conditions. Fine adjustments can be made during installation.

*** Measured 1 metre from the side of the machine.

CONNECTION, MACHINE	WD-12S
Total connected power (kW)	15/18***
Main fuse 400-415V 3N~ (A) *	32/32***
Max. connection area 400-415V 3N~ (L1-L3,N,PE) Cu (mm2) **	25

* Other voltage on request.

** Cable 3 m H07RN-F5G6mm² is included.

*** Option.

WATER, DRAIN AND VENTILATION CONNECTIONS	WD-12S
Water quality, hardness (°dH)	2 - 7
Water connection 5-65°C (external thread) *	R 1/2"
Drain connection, PP pipe (ø mm.)	50
Water capacity, pressure (kPa)	20
Water capacity, flow (litres/min)	10
Floor drain, capacity (litres/sec)	3
Heat load to the room (total, sensible, latent) (kW)	4.9 / 3.6 / 1.3
For machines with the option ECO-FLOW: heat load to the room (total, sensible, latent) (kW)	2.5 / 1.8 / 0.7

* If colder water than 50°C a 15 kW booster heater is recommended.

SIZE AND WEIGHT FOR TRANSPORTATION	WD-12S
Size, LxWxH (mm.)*	1340x860x1730
Weight (kg)*	280

* Packaging included

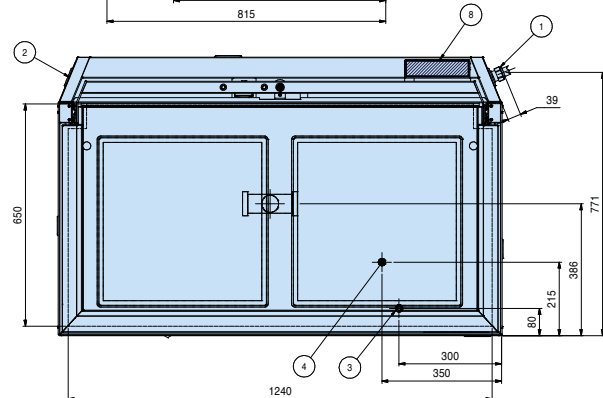
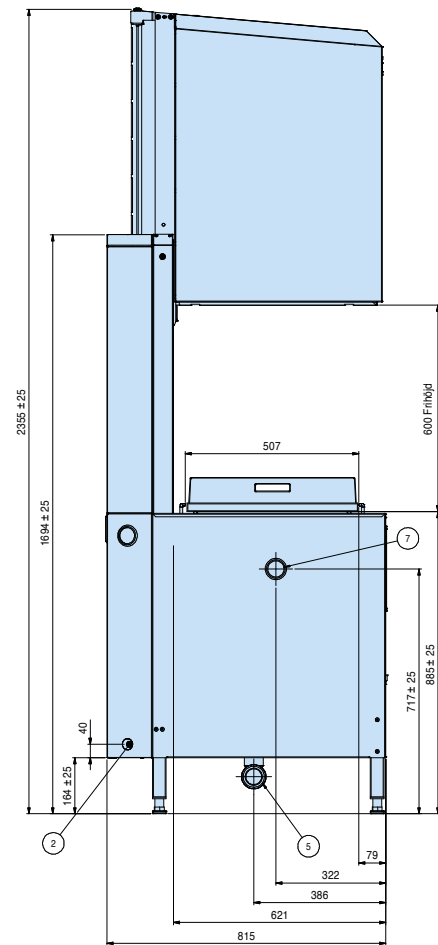
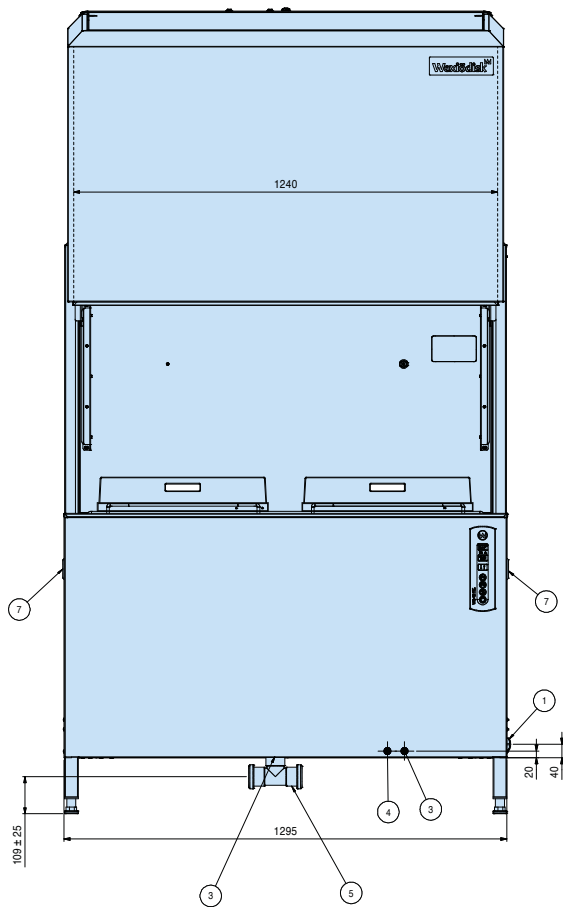

Electrical connection

1. Electrical connection: Cable 3m, H07RN-F 5G6mm²
2. Alternative connection

Water connection

3. Standard: Warm water 50-65° Ext. thread R1/2" 10l/min 0.2 Bar
3. Option Eco-Flow: Cold water 5-12° Ext. thread R1/2" 10l/min 0.2 Bar
4. Option Eco-Flow: Warm water 50-65° Ext. thread R1/2" 10l/min 0.2 Bar

Miscellaneous

5. Drain: Ø50 3l/s capacity
6. Option Drain pump: Flexible hose 2m Ø22
7. Detergent cap
8. Exhaust Eco-Flow

We reserve the right to change technical data.



WD-90 DUO TOUCH

COMBI DISHWASHER

(with or without granules)

- High capacity in small areas. The unique DUO-system makes it easy to switch between normal and heavily soiled items.
- The WD-Touch display guides you through the washing process with an intuitive touch screen. Easy navigation with built-in user manuals.
- No strenuous prewash. Granules scrub away the food residue in the machine.
- Fast drying. Efficient and energy-saving centrifugal spin cycle.
- Robust and durable. Made from stainless steel and high quality components.
- Easy to use – user-friendly panel with a total of nine programmes for normal and heavily soiled items.
- Easy to clean. Improves hygiene.
- Easy to serve. All service is managed from the front or side.
- HACCP documentation – a system that simplifies self checking.
- Ergonomic features. Automatic hood lift means less strain and a better working environment.
- ECO-Flow – Energy efficient heat recovery. The condensing unit removes and recycles the heat from the previous wash (optional).
- Accessories incl in delivery: 1 round potwash cassette, 1 dishwashing basket - flat plates, 1 dishwashing basket - cutlery, 1 dishwashing basket - glasses, cleaning scraper and granules 2x5 kg.



OPTIONS

- Condensing Unit with heat recovery by exhaust steam. The dishwasher is connected only to cold water.
- Web Tool with consumption report
- Marine version 400V/3/50 without neutral
- Marine version 440V/3/60 without neutral
- Drain pump
- Connection power restriction SICOTRONIC
- Dockable loading trolley 900 mm 209.7454

EXTRA EQUIPMENT

- Round potwash cassette (1 pc incl.)
- Washing basket 500 x 500 for plates (1 pc incl. in delivery)
- Washing basket 500 x 500 for cutlery (1 pc incl. in delivery)
- Washing basket 500 x 500 for glasses (1 pc incl. in delivery)
- Granules 2x5 kg (incl. in delivery)
- Cleaning scraper (1 pc incl. in delivery)
- Folding table, right or left
- Folding table, front
- Trolley
- Loading table
- Sous vide basket

ACCESSORIES TO POTWASH CASSETTE

- Holder 209.7277
- Flexibel insert 209.7481
- Rubber strap 209.7272
- Support for pots and pans 209.7252
- Cutlery and utensil holder 209.7251
- Holder for 2/1 containers 209.7484
- Holder for GN 1/3 containers 209.7485
- Holder for GN 1/4 containers 209.7486
- Holder for ABC containers 209.7487
- All-round holder 209.7273
- Holder for small pots 209.7279
- Wire basket for small utensils 209.7278

TECHNICAL DATA	WD-90 DUO TOUCH
Granule wash pump (kW)	2.2
Wash pump pot wash (kW)	1.5
Wash pump (kW)	0.74
Booster heater (kW)	12
Heater tank (kW)	9
Motor rotating table (kW)	0.55
Rinse/booster pump (kW)	0.67
Heat recovery fan (kW)	0.129
Tank volume (litres)	90
Granule amount (kg)	5
Weight machine in operation with condensing unit (kg)	445
Weight machine in operation without condensing unit (kg)	415
Degree of protection (IP)	IP55

CAPACITY AND OPERATION DATA	WD-90 DUO TOUCH
Capacity max number GN 1/1-canteens per wash / Capacity max number GN 1/1-canteens per hour	6 + 1 / 191
Capacity normal wash for glass and china, max number of baskets per hour	46
Normal wash for glass and china	
Programme 1 (min)	1.3
Programme 2 (min)	1.8
Programme 3 (min)	3.3
Heavily soiled wash with granules	
Programme 1 (min)	2.2
Programme 2 (min)	4.2
Programme 3 (min)	6.2

CAPACITY AND OPERATION DATA	WD-90 DUO TOUCH
Heavily soiled wash without granules	
Programme 4 (min)	2.2
Programme 5 (min)	3.7
Programme 6 (min)	6.2
Water consumption/rinse (litres/programme)	4 - 6
Water consumption/cooling (litres/programme)	0 - 1.5
Sound level* (dB(A)) program with granules	70
Max. surface temp. at room temp. 20 degrees C	35

* A-weighted sound pressure level, L_{pA}

CONNECTION, WATER, DRAIN AND VENTILATION	WD-90 DUO TOUCH
Hot water (50 - 65 °C) external thread	1/2"
Cold water (5 - 12 °C) external thread	1/2"
Drain PP-pipe (mm)	Ø 50
Water pressure, max (kPa)	600
Water pressure, min (kPa)	50
Water capacity flow (litres/min)	5
Capacity floor drain (litres/sec)	3
Heat load to the room WD-90 DUO standard (total, sensible, latent) (kW)	1.5 / 1.0 / 0.5
Heat load to the room WD-90 DUO with condensing unit (total, sensible, latent) (kW)	1.2 / 0.7 / 0.5

CONNECTION, MACHINE	WD-90 DUO TOUCH
Total connected power	14.7
Main fuse (400-415V, 3N~, (A)	25
Max. connection area (400-415 V, 3N~ (mm ²)	6

SIZE AND WEIGHT FOR TRANSPORTATION	WD-90 DUO TOUCH
Size L x W x H (mm)	1160 x 950 x 1940/2040
Weight machine incl. packaging (kg)	350
Weight machine + condensing unit incl. packaging (kg)	380

Accessories for WD-90 DUO TOUCH – a selection for different types of dishware



ROUND POTWASH CASSETTE

Capacity 6+1 GN 1/1 65 mm.
The basket is adapted to accommodate canteens of various sizes.
Product no 209.7450

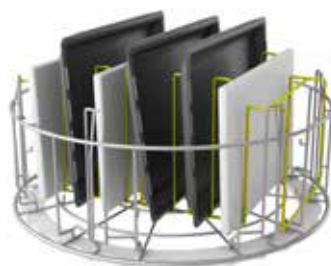

HOLDER

For 2/1 containers, grids and baking plates.
Product no 209.7484



FLEXIBLE INSERT

Product no 209.7481

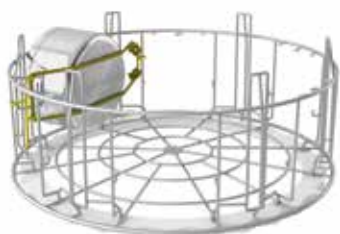

RUBBER STRAP

Product no 209.7272



SUPPORT FOR POTS AND PANS

Product no 209.7252



SOUS VIDE BASKET

Specially designed basket for steel containers that replaces existing disposable and plastic containers. Possible to wash 9 pcs of GN 1/2 + 9 lids, in total 18 items.
Product no 209.7490

CUTLERY AND UTENSIL HOLDER

Product no 209.7251

Extra equipment for WD-90 DUO TOUCH



FOLDING TABLE RIGHT

Product no 209.7452 (right)

FOLDING TABLE LEFT

Product no 209.7453 (left)

FOLDING TABLE FRONT

Product no 209.7451 (front)



TROLLEY

Product no 209.7462



LOADING BENCH

Product no 209.7270



DOCKABLE LOADING TROLLEY 900 MM

Product no 209.7454

**WD-90 DUO TOUCH
standard**

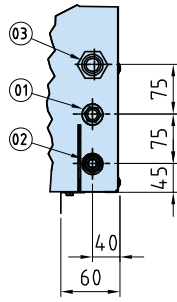
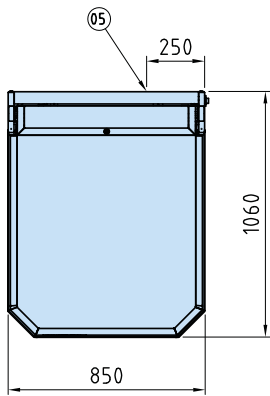

A -

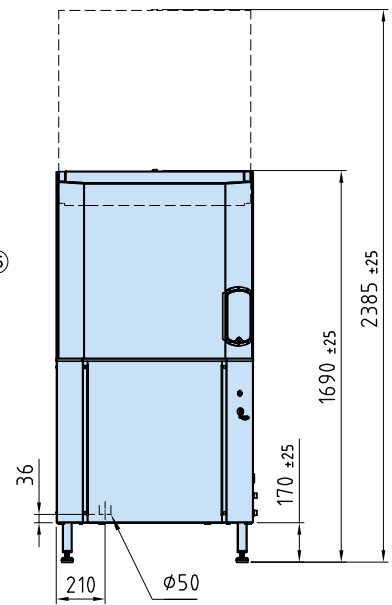
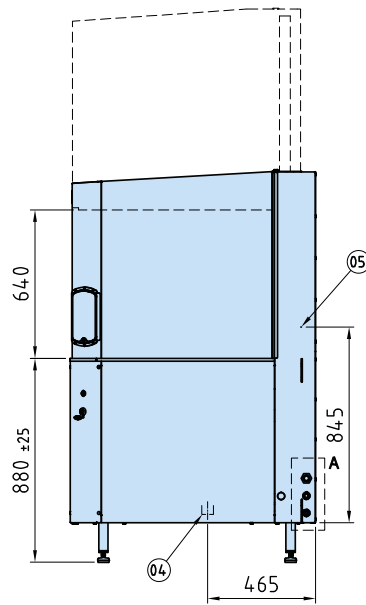

**WD-90 DUO TOUCH
with condensing unit**

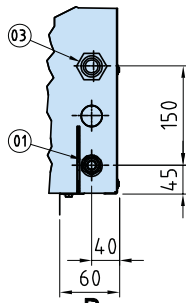
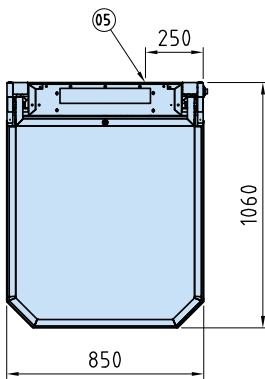

B -

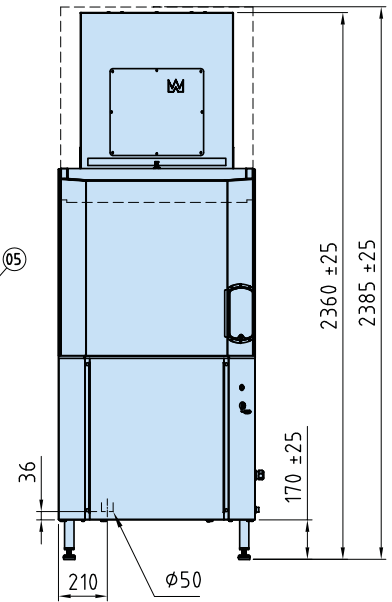
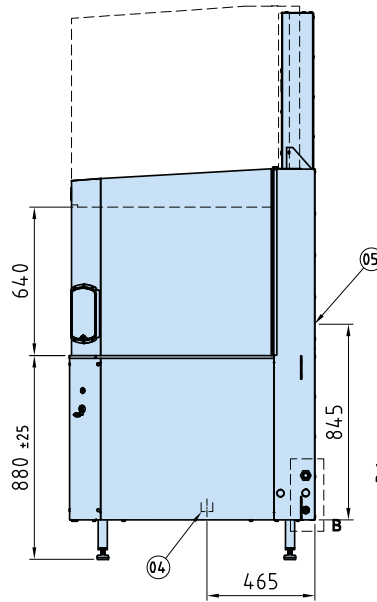

- 01. Cold water connection
- 02. Hot water connection
- 03. Electrical connection
- 04. Drain
- 05. Detergent connection
- 06. Sink connection

We reserve the right to change technical data.

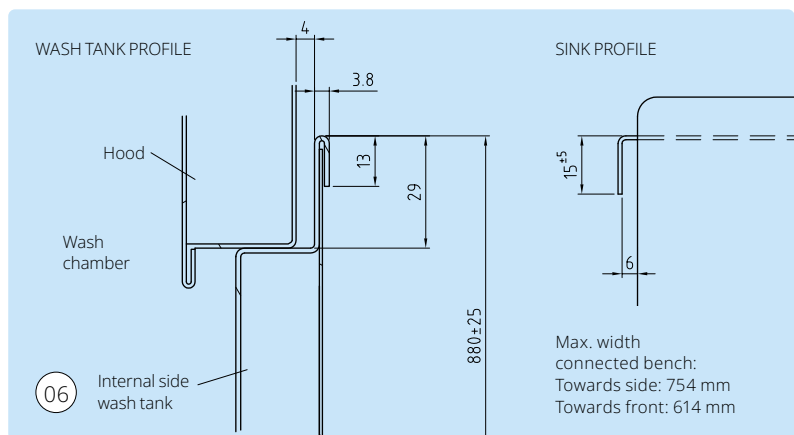

Max. width
connected bench:
Towards side: 754 mm
Towards front: 614 mm



WD-90GR, TOUCH FLEX

POT DISHWASHER

(with or without granules)

- Efficient frontloaded potwasher, washes pots and pans with or without granules.
- The WD-Touch display guides you through the washing process with an intuitive touch screen. Easy navigation with built-in user manuals.
- Excellent washing results and fast drying with efficient and energy saving centrifuging spin cycle.
- Perfect for space efficient installations
- No manual pre-wash or scrubbing thanks to heavy rinsing with water and granules.
- Stacking of goods can be made directly on the hinged door.
- Square washing cassette for containers, holds eight 1/2 or four 1/1 containers.
- Wide range of accessories for various items.
- Accessories for washing 65 and 40 mm-deep 2/1 containers and baking trays 600x400 mm.
- Hinged door enables for easy cleaning.
- Six different wash programs with HACCP function.
- Service can easily be made from the front or side
- Accessories incl in delivery: 1 pc square cassette, 3 pcs support wall, 3 pcs side holder, 1 pc flexibel insert, cleaning scraper and granules 2x5 kg.



OPTIONS

- Condensing unit ECO-FLOW
- Marine version 400V/3/50 without neutral
- Marine version 440V/3/60 without neutral
- Steam heated design, pressure 50-250 kPa
- Booster pump
- Break tank incl. booster pump
- Stainless couplings in the final rinse
- Connection power restriction
- Connection power restriction SICOTRONIC
- External power indication
- Web Tool with HACCP documentation and consumption report
- Drain pump

EXTRA EQUIPMENT

- Table trolley
- Dockable loading trolley 900 mm 209.7454
- Holder for accessories, to be placed on the side of the machine
- Square cassette 209.7296 (1 pc included in the delivery)
- Cassette for canteens with handles
- Cassette for large boxes
- Basket for 4 pc GN 1/1-canteens - 200 mm deep
- Granules 2x5 kg (included in the delivery)
- Cleaning scraper (1 pc included in the delivery)

ACCESSORIES FOR CASSETTES

- All-round holder 209.7273
- Holder for utensils 209.7277
- Wire basket for small utensils 209.7278
- Holder for small pots 209.7279
- Support wall 209.7280 (1 pc included in the delivery)
- Flexible insert, 209.7281, to be used together with 209.7354
- Holder for 1/3, 1/6 and 1/9 containers. 209.7282
- Holder for 1/4, 1/6 containers 209.7286
- Side holder 209.7354
- Rubber strap 209.7272

TECHNICAL DATA	WD-90GR TOUCH FLEX
Granule wash pump (kW)	2.2
Wash pump (kW)	1.5
Motor for the round table (kW)	0,18
Booster heater (kW)	9
Heater tank (kW)	9
Tank volume (litres)	100
Weight, machine in operation (kg)	430
Granule volume (kg)	5
Degree of protection (IP)	IP55

CAPACITY AND OPERATION DATA	WD-90GR TOUCH FLEX
Total time/wash program 1** (min) washing with granules, with spin (can be excluded by technician)	5
Total time/wash program 2** (min) washing with granules, with spin (can be excluded by technician)	8
Total time/wash program 3** (min) washing with granules, with spin (can be excluded by technician)	10.3
Total time/wash program 4** (min) washing without granules, with spin (can be excluded by technician)	2.3
Total time/wash program 5** (min) washing without granules, with spin (can be excluded by technician)	3.8
Total time/wash program 6** (min) washing without granules, with spin (can be excluded by technician)	6.8
Capacity, max (1/1 containers/program)****	4
Capacity, max (1/2 containers/program)****	8
Capacity / h, Pr 1 (1/1-containers) incl. handling ****(pc)	45
Capacity / h, Pr 1 (1/2-containers) incl. handling ****(pc)	90
Water consumption rinse/program (litres) *****	3.5-5

CAPACITY AND OPERATION DATA	WD-90GR TOUCH FLEX
Water consumption cooling/program (litres) *****	0-1.5
Energy consumption (kWh of connected power)	70-90%
Steam consumption *** (kg/h)	15
Sound level* (dB(A)) washing program with granules	69
Max. surface temp. at room temp. 20°C (°C)	30

* A-weighted sound pressure level, LpA

** Factory setting. The wash time is adjustable

*** Steam heated machine

**** Max. capacity depending on the depth of the containers.

***** Applies program using spinning. The water consumption depends on local conditions. An exact adjustment is made during installation.

CONNECTION, ELECTRICALLY HEATED MACHINE	WD-90GR TOUCH FLEX
Total connected power (kW)	11.3
Main fuse 400V 3N~ (A)*	20
Max.conn.area 400V 3N~ (L1-L3,N,PE) Cu (mm ²)	6

* Other voltages on request

CONNECTION, STEAM HEATED MACHINE 50-250 KPA	WD-90GR TOUCH FLEX
Total conn.power (kW)	2.4
Main fuse 400V 3N~(A)*	16
Max.conn.area 400V 3N~(L1-L3, N, PE) Cu (mm ²)	6
Steam connection (internal thread)	R½"
Connection condense water (internal thread)	R½"

* Other voltages on request

CONNECTION WATER, DRAIN AND VENTILATION	WD-90GR TOUCH FLEX
Water quality, hardness (°dH)	2 - 7
Cold water connection 5-12°C (internal thread)	R½"
Hot water connection 50-65°C (internal thread)	R½"
Drain connection, PP pipe (ø mm)	50
Water capacity warm water, pressure (kPa)	250
Water capacity warm water, flow (litres/min)	15
Water capacity cold water cooling, min/max pressure (kPa)	100/160
Floor drain, capacity (litres/sec)	3
Ventilation of the machine (m ³ /h)	600

SIZE AND WEIGHT FOR TRANSPORTATION	WD-90GR TOUCH FLEX
Size * LxWxH (mm)	1060x900x1950
Weight * (kg)	340

* Packaging included

ACCESSORIES FOR WD-90GR TOUCH FLEX



Square shaped cassette, part. no. 209.7276
Included in the delivery.



Side holder, part. no. 209.7354
3 pcs included in the delivery.



Lid holder, part. no. 209.7280
3 pcs included in the delivery.



Flexible insert, part. no. 209.7281
Used together with side holder.
Included in the delivery.



Utensil holder, part. no. 209.7277



Wire basket, part. no. 209.7278



Allround holder, part. no. 209.7273
For pots with handles and ABC-
containers.



Holder for 1/3, 1/6, 1/9 containers,
part. no. 209.7282



Sous vide basket, part. no. 209.7291

The above accessories are a selection of Wexiödisks range. Additional equipment for other kind of dishes can be requested.

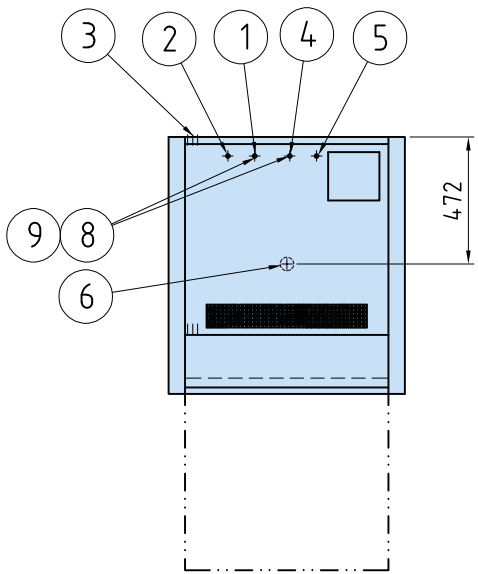
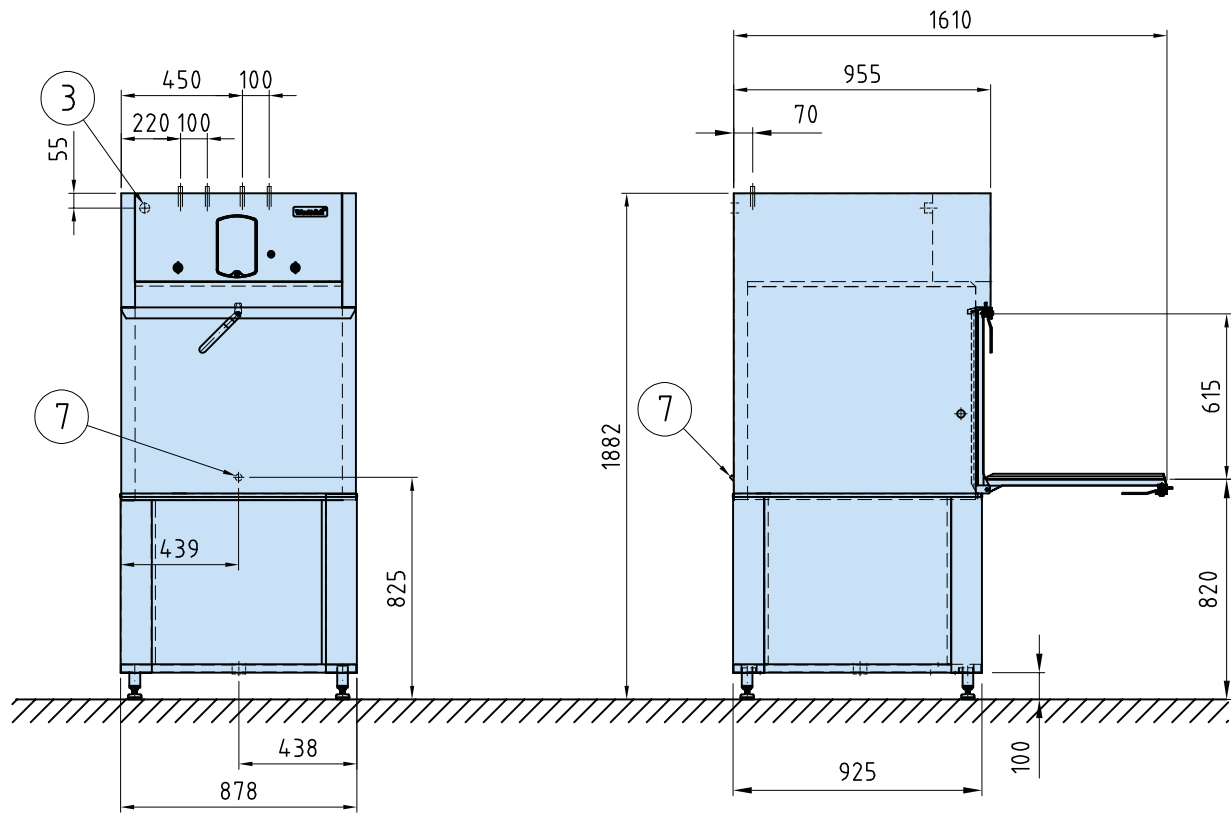

- 1. Cold water connection
- 2. Hot water connection
- 3. Electrical connection
- 4. Steam connection (steam-heated machine)
- 5. Condensation water connection (steam-heated machine)
- 6. Drain connection
- 7. Detergent connection

We reserve the right to change technical data.



WD-90GR, TOUCH HC

POT DISHWASHER

(with or without granules)

- Efficient frontloaded potwasher, washes pots and pans with or without granules.
- The WD-Touch display guides you through the washing process with an intuitive touch screen. Easy navigation with built-in user manuals.
- Excellent washing results and fast drying with efficient and energy saving centrifuging spin cycle.
- Perfect for space efficient installations
- No manual pre-wash or scrubbing thanks to heavy rinsing with water and granules.
- Stacking of goods can be made directly on the hinged door.
- Unique hexagonal cassette with high capacity for washing containers, holds six 1/2 or 1/1 containers.
- Wide range of accessories for various items.
- Accessories for washing 65 and 40 mm-deep 2/1 containers and baking trays 600x400 mm.
- Hinged door enables for easy cleaning.
- Six different wash programs with HACCP function.
- Service can easily be made from the front or side
- Steam reduction through cold water connection – for improved working environment and cooler dishware.
- Accessories incl in delivery: 1 pc hexagonal cassette, 1 pc pot holder, 1 pc holder for 2/1 container, cleaning scraper and granules 2x5 kg.



OPTIONS

- Condensing unit ECO-FLOW
- Marine version 400V/3/50 without neutral
- Marine version 440V/3/60 without neutral
- Steam heated design, pressure 50-250 kPa
- Booster pump
- Break tank incl. booster pump
- Stainless couplings in the final rinse
- Connection power restriction SICOTRONIC
- External power indication
- Web Tool with HACCP documentation and consumption report
- Drain pump

EXTRA EQUIPMENT

- Table trolley
- Dockable loading trolley 900 mm
- Holder for accessories, to be placed on the side of the machine
- Hexagonal cassette 209.7285 (1 pc included in the delivery)
- Cassette for canteens with handles
- Cassette for large boxes
- Basket for 4 pc GN 1/1-canteens - 200 mm deep
- Granules 2x5 kg (included in the delivery)
- Cleaning scraper (1 pc included in the delivery)
- Sous vide basket

ACCESSORIES TO CASSETTES

- Support for pots and pans 209.7252
- ABC container and lid holder 209.7253
- Support for small pots 209.7254
- Holder for large pots 209.7255 (1 pc included in the delivery)
- Pan holder 209.7268
- Rubber strap 209.7272
- Wire basket for small utensils 209.7278
- Holder for small pots 209.7279
- Flexible insert 209.7283
- Holder for 2/1 containers, grids, baking plates - 209.7284 (1 pc included in the delivery)

TECHNICAL DATA	WD-90GR TOUCH HC
Granule wash pump (kW)	2.2
Wash pump (kW)	1.5
Motor for the round table (kW)	0.18
Booster heater (kW)	9
Heater tank (kW)	9
Tank volume (litres)	100
Weight, machine in operation (kg)	430
Granule volume (kg)	5
Degree of protection (IP)	IP55

CAPACITY AND OPERATION DATA	WD-90GR TOUCH HC
Total time/wash program 1** (min) Pr: washing with granules, with spin (can be excluded by technician)	5.2
Total time/wash program 2** (min) Pr: washing with granules, with spin (can be excluded by technician)	8.2
Total time/wash program 3** (min) Pr: washing with granules, with spin (can be excluded by technician)	11
Total time/wash program 4** (min) Pr: washing without granules, with spin (can be excluded by technician)	2.5
Total time/wash program 5** (min) Pr: washing without granules, with spin (can be excluded by technician)	4
Total time/wash program 6** (min) Pr: washing without granules, with spin (can be excluded by technician)	7

CAPACITY AND OPERATION DATA	WD-90GR TOUCH HC
Capacity, max (1/1 containers/program)****	6
Capacity / h, Pr 1 (1/1-containers) incl. handling ****(pc)	68
Capacity / h, Pr 1 (1/2-containers) incl. handling ****(pc)	68
Cold water consumption rinse/program (litres) *****	3.5-5
Water consumption cooling/program (litres) *****	0-1.5
Energy consumption (% of connected power)	70-90%
Steam consumption *** (kg/h)	15
Sound level* (dB(A)) washing program with granules	69
Max. surface temp. at room temp. 20°C (°C)	30

* A-weighted sound pressure level, L_{pA}

** Factory setting. The wash time is adjustable

*** Steam heated machine

**** Max. capacity depending on the depth of the containers.

***** Applies program using spinning. The water consumption depends on local conditions. An exact adjustment is made during installation.

CONNECTION, ELECTRICALLY HEATED MACHINE	WD-90GR HC TOUCH
Total connected power (kW)	11,3
Main fuse 400 V, 3N~ (A)*	20
Max.conn.area 400 V, 3N~, (L1-L3,N,PE) Cu (mm ²)	6

* Other voltages on request

CONNECTION, STEAM HEATED MACHINE 50-250 KPA	WD-90GR TOUCH HC
Total conn.power (kW)	2,4
Main fuse 400 V, 3N~(A)*	16
Max.conn.area 400 V, 3N~, (L1-L3, N, PE) Cu (mm ²)	6
Steam connection (internal thread)	R½"
Connection condense water (internal thread)	R½"

* Other voltages on request

CONNECTION WATER, DRAIN AND VENTILATION	WD-90GR TOUCH HC
Water quality, hardness (°dH)	2 - 7
Cold water connection 5-12°C (internal thread)	R½"
Hot water connection 50-65°C (internal thread)	R½"
Drain connection, PP pipe (ø mm)	50
Water capacity warm water, pressure (kPa)	250
Water capacity warm water, flow (litres/min)	15
Water capacity cold water cooling, min/max pressure (kPa)	100/600
Floor drain, capacity (litres/sec)	3
Ventilation of the machine (m ³ /h)	600

SIZE AND WEIGHT FOR TRANSPORTATION	WD-90GR TOUCH HC
Size * LxWxH (mm)	1060x900x1950
Weight * (kg)	340

* Packaging included

ACCESSORIES FOR WD-90GR TOUCH HC



Hexagonal cassette, part. no. 209.7285
Included in the delivery.



Pot holder, part.no. 209.7255
For large pots. Included in the delivery.



Grid, part. no. 209.7284
For 2/1 containers, grids, baking plates.
Included in the delivery.



Utensil holder, part. no. 209.7251
For hexagonal cassette and round
basket.



Flexible insert, part. no. 209.7283
Rubber rope holder for bowls and pots.



Pot holder for small pots, part. no.
209.7254



ABC- and lid holder, part. no. 209.7253

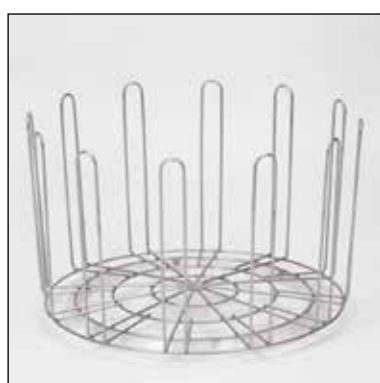

Basket for ABC containers,
part. no. 209.7259



Sous vide basket, part. no. 209.7291

The above accessories are a selection of Wexiödisks range. Additional equipment for other kind of dishes can be requested.

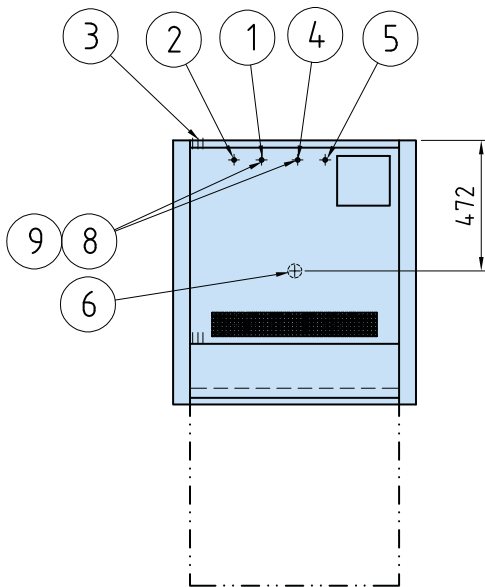
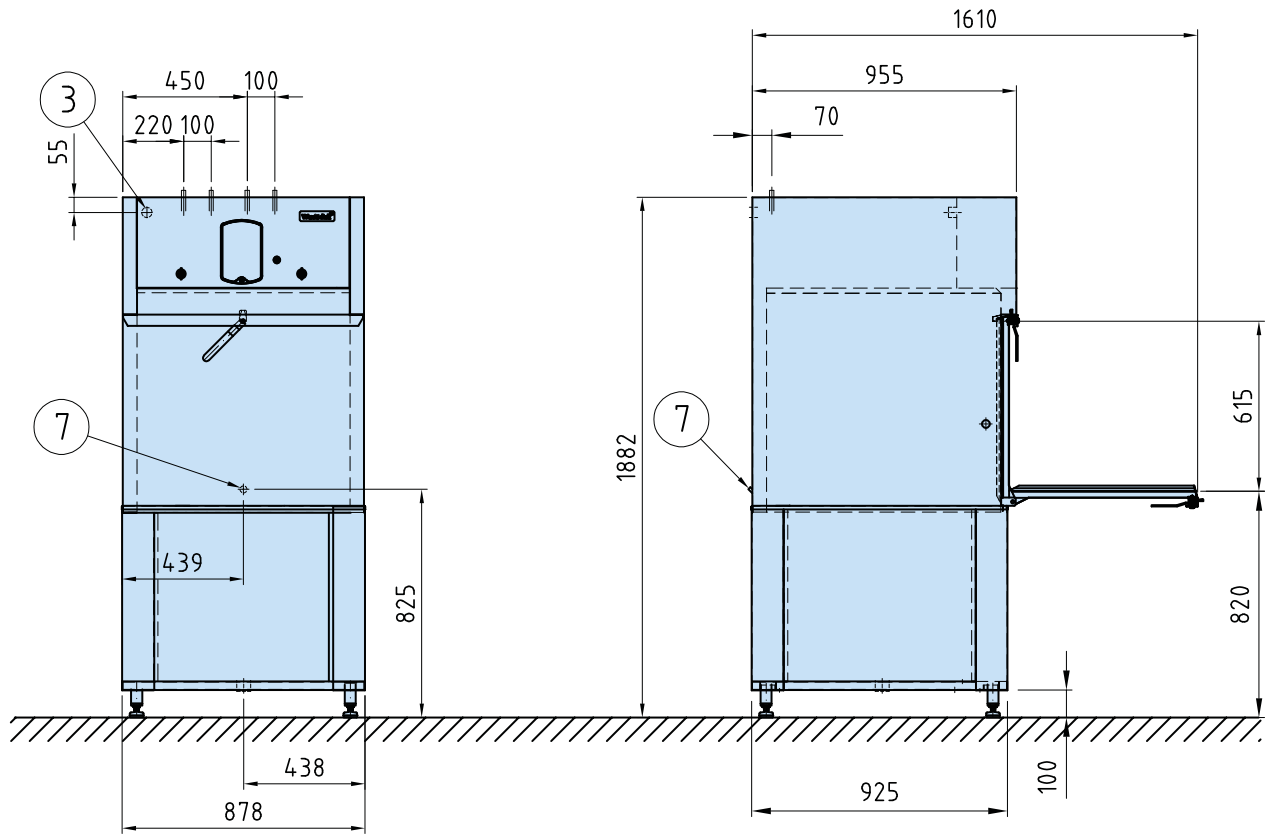

1. Cold water connection/filter R $\frac{1}{2}$ " internal thread, 100-600 kPa, 15l/min
2. Hot water connection/filter R $\frac{1}{2}$ " internal thread, 250 kPa, 15l/min
3. Electrical connection
4. Steam connection (steam-heated machine) R $\frac{1}{2}$ " internal thread, 50-250 kPa
5. Condensate water connection (steam-heated machine) R $\frac{1}{2}$ " internal thread
6. Drain connection 50 mm, 3l/sek
7. Connection for detergent hose, internal \varnothing 16 mm
8. Non return valve
9. Vacuum valve

We reserve the right to change technical data.



WD-100GR TOUCH

POT DISHWASHER, Frontloaded model (with or without granules)

- No manual pre-wash or scrubbing thanks to heavy rinsing with water and granules.
- The WD-Touch display guides you through the washing process with an intuitive touch screen. Easy navigation with built-in user manuals.
- Excellent washing results and fast drying with efficient and energy saving centrifuging spin cycle.
- Heat recovery with condense unit reduces the heat emission.
- Low operating costs – consumes only cold water during operation.
- Complete washing solution with loading table and trolley
- Great selection of accessories to wash various items
- Service friendly - service can be made from the front or side.
- Accessories incl in delivery: 1 pc combi cassette, 3 pcs lid holder, 4 pcs side holders, 3 pcs short runner, 1 pc long runner, cleaning scraper and granules 2x5 kg.



OPTION

- Steam heated design, pressure 50-250 kPa
- Drain pump
- Break tank incl. booster pump
- Stainless couplings in the final rinse
- Connection power restriction
- Connection power restriction Sicotronic
- External power indication
- Panel right side
- Vertically adjustable machine
- Jet pistol with hose L= 6 000 mm.
- Web Tool with HACCP documentation and cost- and consumption report

EXTRA EQUIPMENT

- Combi cassette (1 pcs incl. in delivery)
- Washing cassette for basket 500x500
- Trolley
- Dockable loading trolley 1200 mm 209.7330
- Wall rack for runners
- Wall rack for lid holder
- Wall rack for accessories
- Granules 2x5 kg (included in delivery)
- Scraper (1 pc incl. in delivery)

ACCESSORIES TO CASSETTES

- Lid holder 209.7341 (3 pcs incl. in delivery)
- Long runner 209.7342 (1 pc incl. in delivery)
- Short runner 209.7343 (3 pcs incl. in delivery)
- Allround holder 209.7350
- Flexible insert 209.7351 To be used with side holder 209.7354
- Holder for pots, bows and pans 209.7352
- Utensil holder 209.7353
- Side holder 209.7354 (4 pcs incl. in delivery)
- Holder for canteen with handles 209.7346
- Wire basket for small utensils 209.7357
- Grid 209.7365 for basket 500x500. Used with washing cassette 209.7364
- Holder 209.7366 for GN1/3, 1/6, 1/9 containers
- Cutlery holder 209.7367
- Holder 209.7368 for GN2/8 container

TECHNICAL DATA	WD-100GR TOUCH
Granule wash pump (kW)	2x2.2
Wash pump (kW)	2.2
Motor for the round table (kW)	0.37
Door drive motors (kW)	2x0.13
Booster heater (kW)	9
Heater tank (kW)	12
Condensing fan (kW)	0.12
Condensing fan, capacity (m ³ /h)	300
Heat recovery unit, cooling area (m ²)	11
Tank volume (litres)	145
Weight, machine in operation (kg)	685
Granule volume (kg)	10
Degree of protection (IP)	IP55
Booster pump (kW)	0.58
Drain pump (kW)	0.17

CAPACITY AND OPERATION DATA	WD-100GR TOUCH
Total time/wash program 1* (min) Pr: washing with granules, with spin (can be excluded by technician)	5.3
Total time/wash program 2* (min) Pr: washing with granules, with spin (can be excluded by technician)	8.3
Total time/wash program 3* (min) Pr: washing with granules, with spin (can be excluded by technician)	11.1
Total time/wash program 4* (min) Pr: washing without granules, with spin (can be excluded by technician)	2.6
Total time/wash program 5* (min) Pr: washing without granules, with spin (can be excluded by technician)	4.1
Total time/wash program 6* (min) Pr: washing without granules, with spin (can be excluded by technician)	7.1
Capacity, max (1/1 containers/program)**	8
Capacity / h, Pr 1 (1/1-containers) incl. handling **(pc)	90
Capacity / h, Pr 1 (1/2-containers) incl. handling **(pc)	181
Cold water consumption rinse/program (litres) ***	6

CAPACITY AND OPERATION DATA	WD-100GR TOUCH
Energy consumption (% of connected power)	70-90%
Steam consumption **** (kg/h)	30
Sound level (dB(A)) program with granules (A-weighted sound pressure level, L _{pA})	70
Max. surface temp. at room temp. 20°C (°C)	35

CONNECTION, ELECTRICALLY HEATED MACHINE	WD-100GR TOUCH
Total connected power (kW)	21
Main fuse 400 V, 3N~ (A) *****	35
Max.conn.area 400 V, 3N~, (L1-L3,N,PE) Cu (mm ²)	35

CONNECTION, STEAM HEATED MACHINE 50-250 KPA	WD-100GR TOUCH
Total conn.power (kW)	4.8
Main fuse 400 V, 3N~(A) *****	16
Max.conn.area 400 V, 3N~, (L1-L3, N, PE) Cu (mm ²)	35
Steam connection (internal thread)	R1"
Connection condense water (internal thread)	R½"

CONNECTION WATER, DRAIN AND VENTILATION	WD-100GR TOUCH
Water quality, hardness (°dH)	2 - 7
Cold water connection 5-12°C (internal thread)	R½"
Hot water connection 50-65°C (internal thread)	R½"
Drain connection, PP pipe (ø mm)	50
Water capacity cold water, pressure (kPa)	200
Water capacity cold water, flow (litres/min)	18
Water capacity hot water, min/max pressure (kPa)	100/600
Floor drain, capacity (litres/sec)	3
Ventilation of the machine (m ³ /h)	900

SIZE AND WEIGHT FOR TRANSPORTATION	WD-100GR TOUCH
Size LxWxH (mm)	1220x1320x2300
Weight (kg), packaging included	555

* Factory setting. The wash time is adjustable

** Max. capacity depending on the depth of the containers.

*** Applies program using spinning. The water consumption depends on local conditions. An exact adjustment is made during installation.

**** Steam heated machine

***** Other voltages on request

ACCESSORIES FOR WD-100GR TOUCH



Washing cassette. Part. no. 209.7340
Included in the delivery.

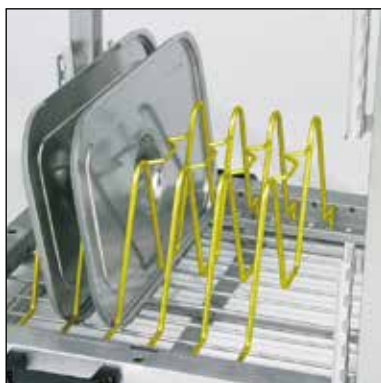

Lid holder. Part. no. 209.7341
Included in the delivery.



Side holder. Part. no. 209.7354
Included in the delivery.



Utensil holder. Part. no. 209.7353
For utensils max 650 mm high.



Wire basket
Part. no. 209.7357



Holder for 1/3-, 1/6- and 1/9-containers
Part. no. 209.7366



ABC container holder.
Part. no. 209.7356

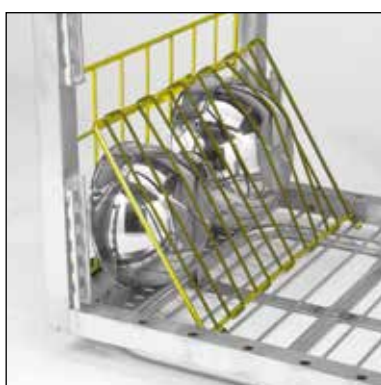

Flexible insert. Part. no. 209.7351
Used together with side holder.

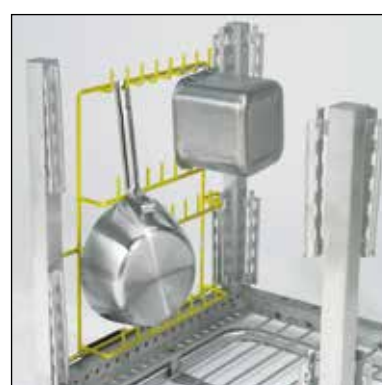

Allround holder
Part. no. 209.7350

The above accessories are a selection of Wexiödisks range. Additional equipment for other kind of dishes can be requested.

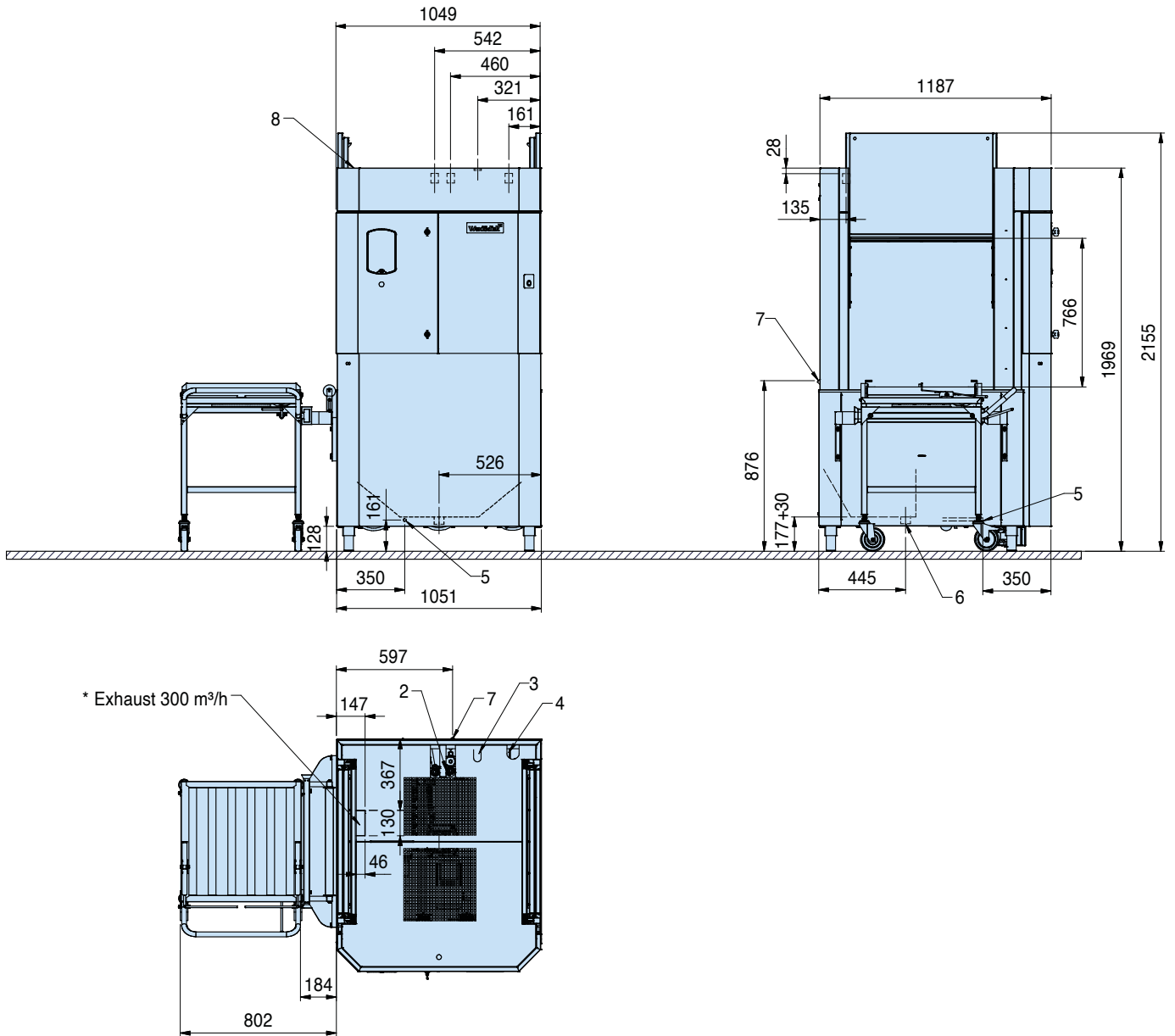

* Exhaust 300 m³/h

1. Cold water connection 5-12°C, 250-500 kPa
2. Hot water connection 50-65°C, 250-500 kPa
3. Electrical connection, electrical heated 400 V, 3N, 21 kW, 35 A
steam heated 400 V, 3N, 4,8 kW, 16 A
4. Steam connection 50-250 kPa
(steam-heated machine)
5. Condensate water connection 90-95"
(steam-heated machine)
6. Drain connection 50 mm
7. Connection for detergent hose
8. General ventilation requirements 900 m³/h *10 sec at the beginning of
the wash cycle and 50 sec starting 10 sec after the final rinse starts.



WD-100GR TOUCH

POT DISHWASHER, Pass-through model (with or without granule)

- No manual pre-wash or scrubbing thanks to heavy rinsing with water and granules.
- The WD-Touch display guides you through the washing process with an intuitive touch screen. Easy navigation with built-in user manuals.
- Excellent washing results and fast drying with efficient and energy saving centrifuging spin cycle.
- Unique through-feed machine for good ergonomics and hygiene. Can be delivered as frontloaded model for compact installations.
- Heat recovery with condense unit reduces the heat emission.
- Low operating costs – consumes only cold water during operation.
- Efficient washing with high capacity thanks to the double rinse system.
- Complete washing solution with loading table and trolley
- Great selection of accessories to wash various items
- Service friendly - service can be made from the front or side.
- Accessories incl in delivery: 2 pcs combi cassette, 6 pcs lid holder, 2 pcs long runner, 6 pcs short runner, 4 pcs side holders, cleaning scraper and granul 2x5 kg.



OPTION

- Steam heated design, pressure 50-250 kPa
- Drain pump
- Break tank incl. booster pump
- Stainless couplings in the final rinse
- Connection power restriction
- Connection power restriction Sicotronic
- External power indication
- Panel right side
- Vertically adjustable machine
- Jet pistol with hose L= 6 000 mm.
- Web Tool with HACCP documentation and cost- and consumption report

EXTRA EQUIPMENT

- Combi cassette (2 pcs incl. in delivery)
- Washing cassette for basket 500x500
- Trolley
- Dockable loading trolley 1200 mm 209.7330
- Wall rack for runners
- Wall rack for lid holder
- Wall rack for accessories
- Granules 2x5 kg (included in delivery)
- Scraper (1 pc incl. in delivery)

ACCESSORIES TO CASSETTES

- Lid holder 209.7341 (6 pcs incl. in delivery)
- Long runner 209.7342 (2 pcs incl. in delivery)
- Short runner 209.7343 (6 pcs incl. in delivery)
- Allround holder 209.7350
- Flexible insert 209.7351 To be used with side holder 209.7354
- Holder for pots, bows and pans 209.7352
- Utensil holder 209.7353
- Side holder 209.7354 (4 pcs incl. in delivery)
- Holder for canteen with handles 209.7356
- Wire basket for small utensils 209.7357
- Grid 209.7365 for basket 500x500. Used with washing cassette 209.7364
- Holder 209.7366 for GN1/3, 1/6, 1/9 containers
- Cutlery holder 209.7367
- Holder 209.7368 for GN2/8 container

TECHNICAL DATA	WD-100GR TOUCH
Granule wash pump (kW)	2x2.2
Wash pump (kW)	2.2
Motor for the round table (kW)	0.37
Door drive motors (kW)	2x0.13
Booster heater (kW)	9
Heater tank (kW)	12
Condensing fan (kW)	0.12
Condensing fan, capacity (m ³ /h)	300
Heat recovery unit, cooling area (m ²)	11
Tank volume (litres)	145
Weight, machine in operation (kg)	685
Granule volume (kg)	10
Degree of protection (IP)	IP55
Booster pump (kW)	0.58
Drain pump (kW)	0.17

CAPACITY AND OPERATION DATA	WD-100GR TOUCH
Total time/wash program 1* (min) Pr: washing with granules, with spin (can be excluded by technician)	5.3
Total time/wash program 2* (min) Pr: washing with granules, with spin (can be excluded by technician)	8.3
Total time/wash program 3* (min) Pr: washing with granules, with spin (can be excluded by technician)	11.1
Total time/wash program 4* (min) Pr: washing without granules, with spin (can be excluded by technician)	2.6
Total time/wash program 5* (min) Pr: washing without granules, with spin (can be excluded by technician)	4.1
Total time/wash program 6* (min) Pr: washing without granules, with spin (can be excluded by technician)	7.1
Capacity, max (1/1 containers/program)**	8
Capacity / h, Pr 1 (1/1-containers) incl. handling **(pc)	90
Capacity / h, Pr 1 (1/2-containers) incl. handling **(pc)	181
Cold water consumption rinse/program (litres) ***	6

CAPACITY AND OPERATION DATA	WD-100GR TOUCH
Energy consumption (% of connected power)	70-90%
Steam consumption **** (kg/h)	30
Sound level (dB(A)) program with granules (A-weighted sound pressure level, L _{pA})	70
Max. surface temp. at room temp. 20°C (°C)	35

CONNECTION, ELECTRICALLY HEATED MACHINE	WD-100GR TOUCH
Total connected power (kW)	21
Main fuse 400 V, 3N~ (A) *****	35
Max.conn.area 400 V, 3N~, (L1-L3,N,PE) Cu (mm ²)	35

CONNECTION, STEAM HEATED MACHINE 50-250 KPA	WD-100GR TOUCH
Total conn.power (kW)	4.8
Main fuse 400 V, 3N~(A) *****	16
Max.conn.area 400 V, 3N~, (L1-L3, N, PE) Cu (mm ²)	35
Steam connection (internal thread)	R1"
Connection condense water (internal thread)	R½"

CONNECTION WATER, DRAIN AND VENTILATION	WD-100GR TOUCH
Water quality, hardness (°dH)	2 - 7
Cold water connection 5-12°C (internal thread)	R½"
Hot water connection 50-65°C (internal thread)	R½"
Drain connection, PP pipe (ø mm)	50
Water capacity cold water, pressure (kPa)	200
Water capacity cold water, flow (litres/min)	18
Water capacity hot water, min/max pressure (kPa)	100/600
Floor drain, capacity (litres/sec)	3
Ventilation of the machine (m ³ /h)	900

SIZE AND WEIGHT FOR TRANSPORTATION	WD-100GR TOUCH
Size LxWxH (mm)	1220x1320x2300
Weight (kg), packaging included	555

* Factory setting. The wash time is adjustable

** Max. capacity depending on the depth of the containers.

*** Applies program using spinning. The water consumption depends on local conditions. An exact adjustment is made during installation.

**** Steam heated machine

***** Other voltages on request

ACCESSORIES WD-100GR TOUCH

(pass-through model)

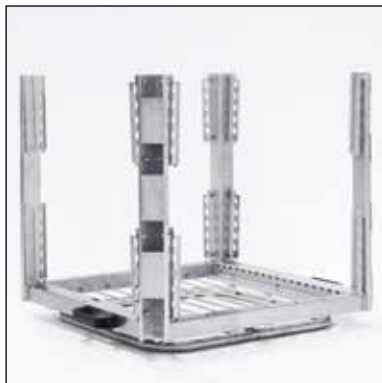

Washing cassette. Part. no. 209.7340
Included in the delivery.

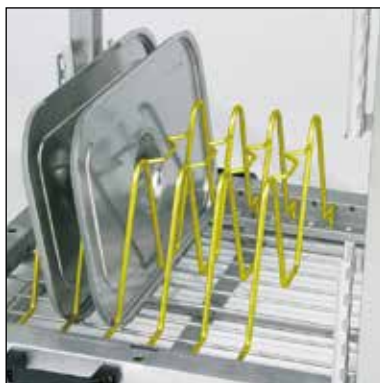

Lid holder. Part. no. 209.7341
Included in the delivery.



Side holder. Part. no. 209.7354
Included in the delivery.



Utensil holder. Part. no. 209.7353
For utensils max 650 mm high.



Wire basket
Part. no. 209.7357



Holder for 1/3-, 1/6- and 1/9-containers
Part. no. 209.7366



ABC container holder.
Part. no. 209.7356

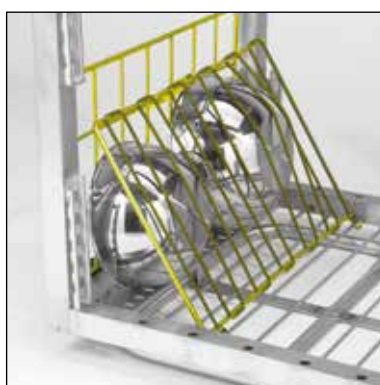

Flexible insert. Part. no. 209.7351
Used together with side holder.



Allround holder
Part. no. 209.7350

The above accessories are a selection of Wexiödisks range. Additional equipment for other kind of dishes can be requested.

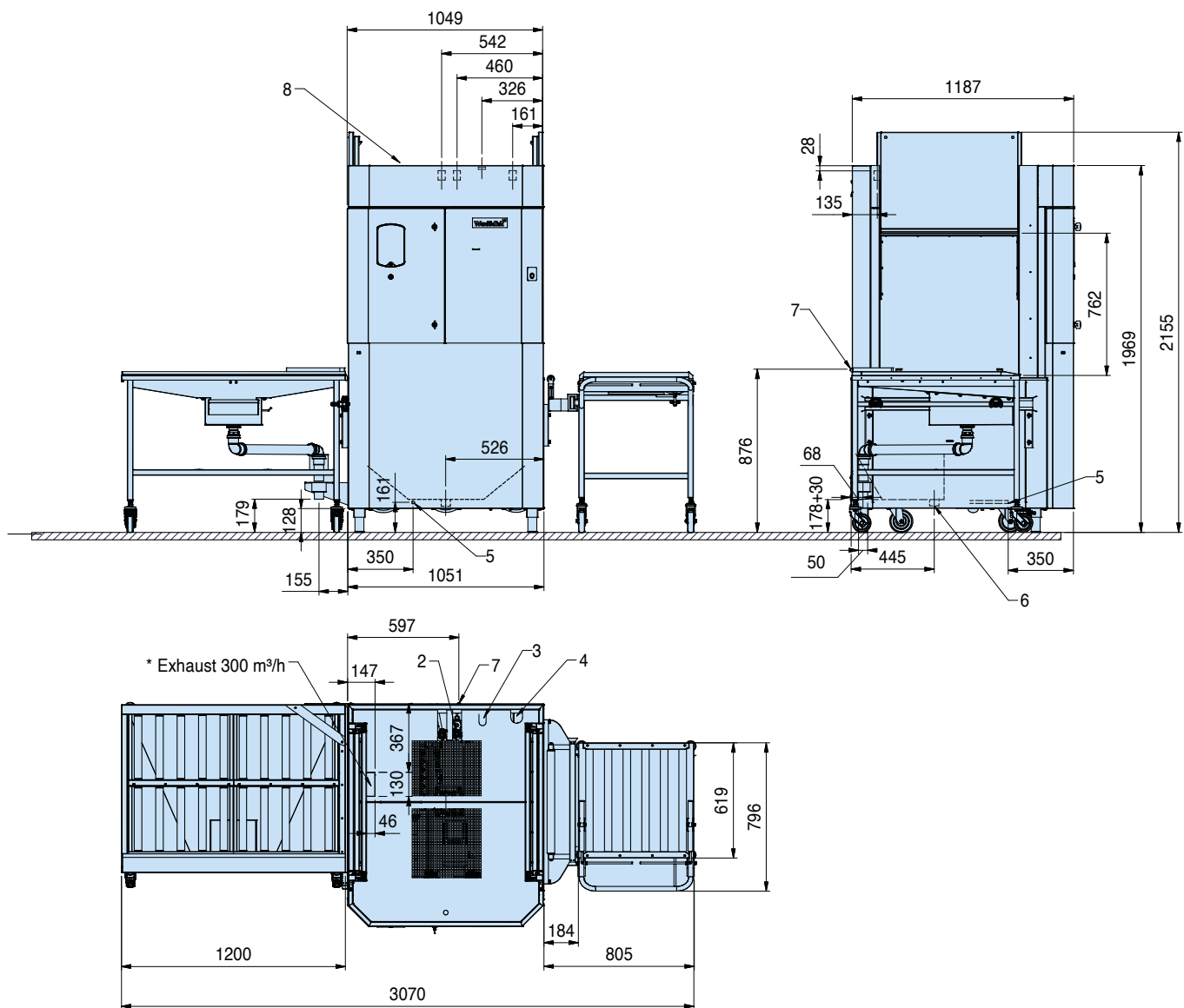

1. Cold water connection 5-12°C, 250-500 kPa
2. Hot water connection 50-65°C, 250-500 kPa
3. Electrical connection, electrical heated 400 V, 3N, 21 kW, 35 A
steam heated 400 V, 3N, 4,8 kW, 16 A
4. Steam connection 50-250 kPa
(steam-heated machine)
5. Condensate water connection 90-95"
(steam-heated machine)
6. Drain connection 50 mm
7. Connection for detergent hose
8. General ventilation requirements 900 m³/h *10 sec at the beginning of the wash cycle and 50 sec starting 10 sec after the final rinse starts.

We reserve the right to change technical data.

По вопросам продаж и поддержки обращайтесь:

Алматы (727)345-47-04
Ангарск (3955)60-70-56
Архангельск (8182)63-90-72
Астрахань (8512)99-46-04
Барнаул (3852)73-04-60
Белгород (4722)40-23-64
Благовещенск (4162)22-76-07
Брянск (4832)59-03-52
Владивосток (423)249-28-31
Владикавказ (8672)28-90-48
Владимир (4922)49-43-18
Волгоград (844)278-03-48
Вологда (8172)26-41-59
Воронеж (473)204-51-73
Екатеринбург (343)384-55-89

Иваново (4932)77-34-06
Ижевск (3412)26-03-58
Иркутск (395)279-98-46
Казань (843)206-01-48
Калининград (4012)72-03-81
Калуга (4842)92-23-67
Кемерово (3842)65-04-62
Киров (8332)68-02-04
Коломна (4966)23-41-49
Кострома (4942)77-07-48
Краснодар (861)203-40-90
Красноярск (391)204-63-61
Курск (4712)77-13-04
Курган (3522)50-90-47
Липецк (4742)52-20-81

Магнитогорск (3519)55-03-13
Москва (495)268-04-70
Мурманск (8152)59-64-93
Набережные Челны (8552)20-53-41
Нижний Новгород (831)429-08-12
Новокузнецк (3843)20-46-81
Ноябрьск (3496)41-32-12
Новосибирск (383)227-86-73
Омск (3812)21-46-40
Орел (4862)44-53-42
Оренбург (3532)37-68-04
Пенза (8412)22-31-16
Петрозаводск (8142)55-98-37
Псков (8112)59-10-37
Пермь (342)205-81-47

Ростов-на-Дону (863)308-18-15
Рязань (4912)46-61-64
Самара (846)206-03-16
Санкт-Петербург (812)309-46-40
Саратов (845)249-38-78
Севастополь (8692)22-31-93
Саранск (8342)22-96-24
Симферополь (3652)67-13-56
Смоленск (4812)29-41-54
Сочи (862)225-72-31
Ставрополь (8652)20-65-13
Сургут (3462)77-98-35
Сыктывкар (8212)25-95-17
Тамбов (4752)50-40-97
Тверь (4822)63-31-35

Тольятти (8482)63-91-07
Томск (3822)98-41-53
Тула (4872)33-79-87
Тюмень (3452)66-21-18
Ульяновск (8422)24-23-59
Улан-Удэ (3012)59-97-51
Уфа (347)229-48-12
Хабаровск (4212)92-98-04
Чебоксары (8352)28-53-07
Челябинск (351)202-03-61
Череповец (8202)49-02-64
Чита (3022)38-34-83
Якутск (4112)23-90-97
Ярославль (4852)69-52-93

Россия +7(495)268-04-70

Казахстан +7(727)345-47-04

Беларусь +(375)257-127-884

Узбекистан +998(71)205-18-59

Киргизия +996(312)96-26-47

эл.почта: wkd@nt-rt.ru || сайт: <https://wexiodisk.nt-rt.ru/>