

Посудомоечные машины капотного типа WD

Технические характеристики

По вопросам продаж и поддержки обращайтесь:

Алматы (727)345-47-04
Ангарск (3955)60-70-56
Архангельск (8182)63-90-72
Астрахань (8512)99-46-04
Барнаул (3852)73-04-60
Белгород (4722)40-23-64
Благовещенск (4162)22-76-07
Брянск (4832)59-03-52
Владивосток (423)249-28-31
Владикавказ (8672)28-90-48
Владимир (4922)49-43-18
Волгоград (844)278-03-48
Вологда (8172)26-41-59
Воронеж (473)204-51-73
Екатеринбург (343)384-55-89

Иваново (4932)77-34-06
Ижевск (3412)26-03-58
Иркутск (395)279-98-46
Казань (843)206-01-48
Калининград (4012)72-03-81
Калуга (4842)92-23-67
Кемерово (3842)65-04-62
Киров (8332)68-02-04
Коломна (4966)23-41-49
Кострома (4942)77-07-48
Краснодар (861)203-40-90
Красноярск (391)204-63-61
Курск (4712)77-13-04
Курган (3522)50-90-47
Липецк (4742)52-20-81

Магнитогорск (3519)55-03-13
Москва (495)268-04-70
Мурманск (8152)59-64-93
Набережные Челны (8552)20-53-41
Нижний Новгород (831)429-08-12
Новокузнецк (3843)20-46-81
Ноябрьск (3496)41-32-12
Новосибирск (383)227-86-73
Омск (3812)21-46-40
Орел (4862)44-53-42
Оренбург (3532)37-68-04
Пенза (8412)22-31-16
Петрозаводск (8142)55-98-37
Псков (8112)59-10-37
Пермь (342)205-81-47

Ростов-на-Дону (863)308-18-15
Рязань (4912)46-61-64
Самара (846)206-03-16
Санкт-Петербург (812)309-46-40
Саратов (845)249-38-78
Севастополь (8692)22-31-93
Саранск (8342)22-96-24
Симферополь (3652)67-13-56
Смоленск (4812)29-41-54
Сочи (862)225-72-31
Ставрополь (8652)20-65-13
Сургут (3462)77-98-35
Сыктывкар (8212)25-95-17
Тамбов (4752)50-40-97
Тверь (4822)63-31-35

Тольятти (8482)63-91-07
Томск (3822)98-41-53
Тула (4872)33-79-87
Тюмень (3452)66-21-18
Ульяновск (8422)24-23-59
Улан-Удэ (3012)59-97-51
Уфа (347)229-48-12
Хабаровск (4212)92-98-04
Чебоксары (8352)28-53-07
Челябинск (351)202-03-61
Череповец (8202)49-02-64
Чита (3022)38-34-83
Якутск (4112)23-90-97
Ярославль (4852)69-52-93

Россия +7(495)268-04-70

Казахстан +7(727)345-47-04

Беларусь +(375)257-127-884

Узбекистан +998(71)205-18-59

Киргизия +996(312)96-26-47

эл.почта: wkd@nt-rt.ru || сайт: <https://wexiodisk.nt-rt.ru/>

WD-6

HOOD TYPE DISHWASHER

FEATURES

- Robust and reliable design in stainless steel with components that guarantee a durable and reliable operation for many years
- The machine has an energy saving heat and sound insulating double-skinned hood.
- A good working environment with the unique hood concept
- High levels of hygiene with an automatic cleaning programme and guaranteed rinse temperature by thermal stop system
- Self-drained wash pump
- Large deep tank to protect against foaming
- Easy servicing - the machine is serviced from the front
- Hygiene control – control system with integrated HACCP
- Excellent wash results – with selfdraining washing arms
- Powerful washing pressure with anti-blocking nozzles
- Individual adjustable wash- and rinse times as well as temperatures for each programme
- Inbuilt dosing pump for fine dosage of rinse aid
- Automatic cleaning program



OPTIONS

- Automatic hood
- Autostart for automatic hood
- 230V/1/50Hz
- 230V/3/50Hz
- Marine version
- Detergent pump for liquid detergent
- Panel on left side
- Lockable cabinet for chemicals (not in comb. with break tank or panel on left side)
- Booster heater for cold water connection
- Drain pump
- Separate filling of tank
- Break tank with booster pump (to be used when no external resuction protection is mounted)
- Booster pump connected with WD-PRM6 equipped with automatic hood (In combination with break tank)
- ECO-FLOW condensing unit with heat recovery by the exhausted steam. (cold water connection is required)
- Heat exchanger with heat recovery by the drain water. Not in combination with PRM. (cold water connection is required)
- WEB Tool - For external HACCP documentation

EXTRA EQUIPMENT

- Steam hood with suction connection
- Shelf for chemical storage
- Sideboard (560 x 560 mm)

TECHNICAL DATA	WD-6
Wash pump (kW)	0.9
Booster heater (kW)	9/12*
Heater tank (kW)	1.8
Tank volume (litres)	50
Weight, machine in operation (kg)	160
Degree of protection (IP)	45

* 12 kW booster heater is optional.

CAPACITY AND OPERATION DATA	WD-6
Total time/wash program 1 (min)	1.2**
Total time/wash program 2 (min)	1.7**
Total time/wash program 3 (min)	3.2**
Capacity, max (baskets/h)	50
Water consumption rinse/program (litres)	2.5-4***
Energy consumption (kWh of connected power)	70-90%
Sound level* (dB(A))	60

* Measured 1 metre from the machine.

** Factory setting. The wash time is adjustable.

*** The water consumption depends on local conditions. An exact adjustment is made during installation.

CONNECTION, MACHINE	WD-6
Total connected power (kW)	9.9/12.9*
Main fuse 400V 3N~ (A)**	16/25*
Max connection area 400V 3N~(L1-L3, N, PE) Cu (mm2)***	2.5

* 12 kW booster heater is optional.

** Other voltages on request.

*** Cabel 2.5m H07RN-F included.

CONNECTION WATER, DRAIN AND VENTILATION	WD-6
Water quality, hardness (°dH)	2-7
Water connection 5-65°C (external thread)*	R 1/2"
Drain connection, PP pipe (ø mm)	50
Water capacity, pressure (kPa)	180**
Water capacity, flow (litres/min)	18
Water capacity hood lift, pressure (kPa)	180**
Floor drain, capacity (litres/sec)	3
Heat load to the room (total, sensible, latent) (kW)	2.3 / 1.7 / 0.6
For machines with the option ECO-FLOW: heat load to the room (total, sensible, latent) (kW)	1.2 / 0.9 / 0.3

* If colder water than 55° C a 12 kW booster heater is recommended.
 ** If pressure / flow is lower the machine should be equipped with a break tank.

SIZE AND WEIGHT FOR TRANSPORTATION	WD-6
Size LxWxH (mm) *	765x710x1560
Weight (kg) *	115

* Packaging included.

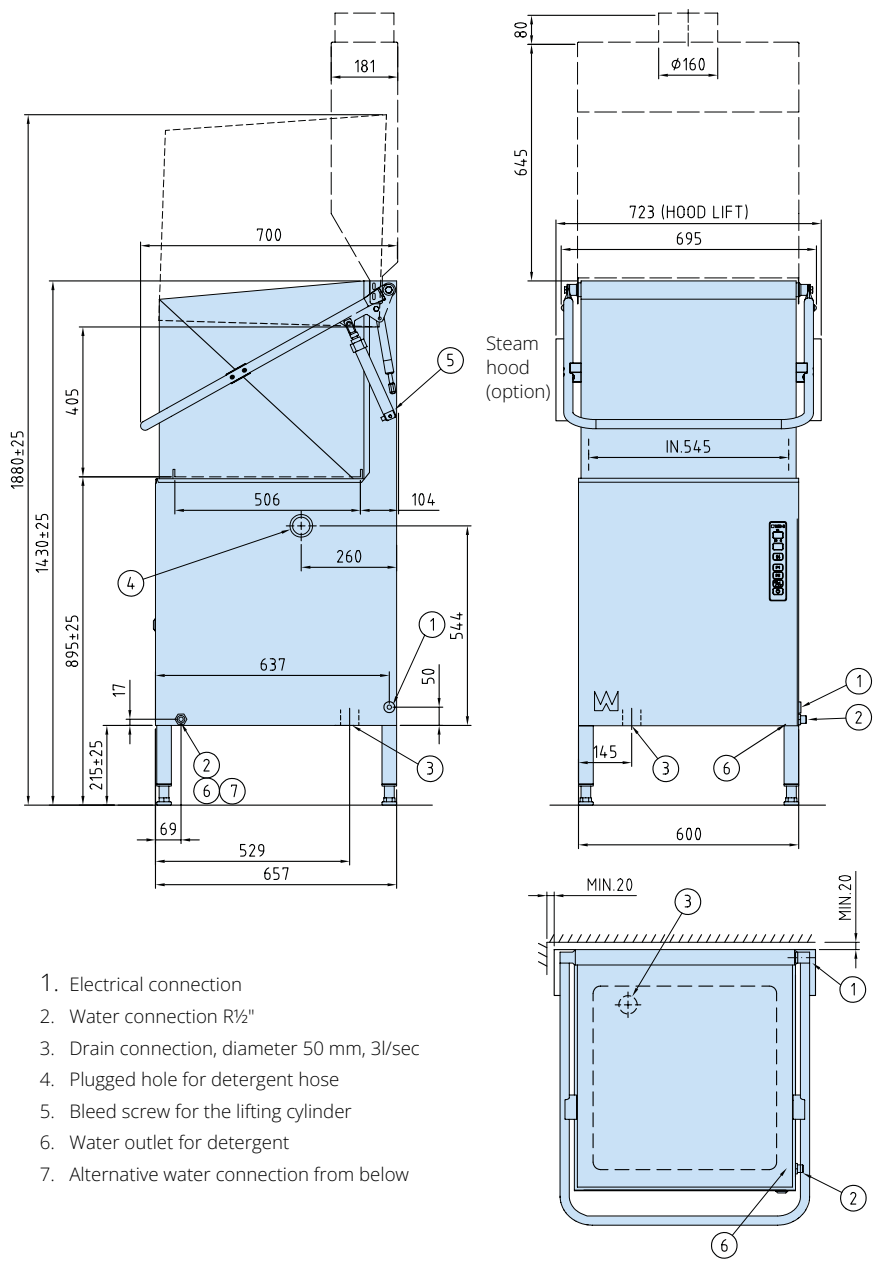

1. Electrical connection
2. Water connection R1/2"
3. Drain connection, diameter 50 mm, 3l/sec
4. Plugged hole for detergent hose
5. Bleed screw for the lifting cylinder
6. Water outlet for detergent
7. Alternative water connection from below

WD-6 with **ECO-FLOW** condensing unit and heat exchanger

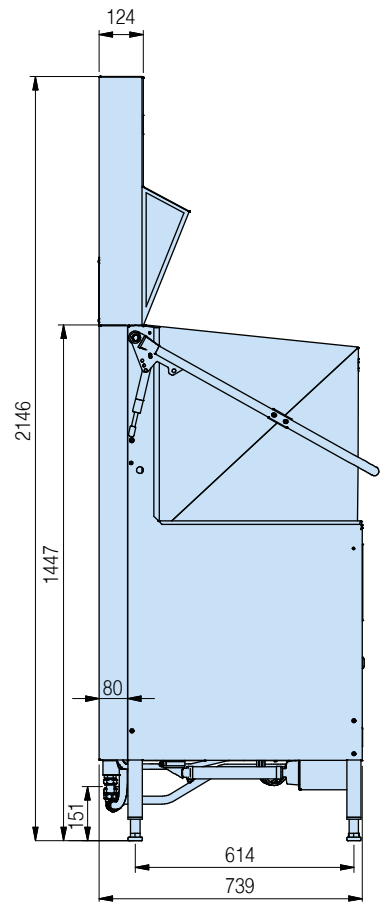

WD-6 DUPLUS

HOOD TYPE DISHWASHER

FEATURES

- Double final rinse with DUPLUS technology – Improved rinsing results using less fresh water.
- High efficiency with low operating costs – DUPLUS technology reduces the consumption of fresh water, chemicals and electricity.
- Particularly large cost savings – if osmosis water has to be used.
- Robust and reliable design in stainless steel with components that guarantee a durable and reliable operation for many years.
- The machine has an energy saving heat and sound insulating double-skinned hood.
- A good working environment with the unique hood concept.
- High levels of hygiene with an automatic cleaning programme and guaranteed rinse temperature by thermal stop system.
- Self-drained wash pump.
- Large deep tank to protect against foaming.
- Easy servicing - the machine is serviced from the front.
- Hygiene control – control system with integrated HACCP.
- Excellent wash results – with selfdraining washing arms.
- Powerful washing pressure with anti-blocking nozzles.
- Individual adjustable wash- and rinse times as well as temperatures for each programme .
- Inbuilt dosing pump for fine dosage of rinse aid.
- Break tank with booster pump.
- Automatic cleaning program.



OPTIONS

- Automatic hood.
- Autostart for automatic hood.
- 230V/3/50Hz
- Marine version.
- Detergent pump for liquid detergent.
- Panel on left side.
- Drain pump.
- Double water connection hot/cold.
- Booster pump connected with WD-PRM6 equipped with automatic hood (In combination with break tank).
- ECO-FLOW condensing unit with heat recovery by the exhausted steam. (cold water connection is required).
- WEB Tool - For external HACCP documentation.

EXTRA EQUIPMENT

- Steam hood with suction connection.
- Shelf for chemical storage.
- Sideboard (560 x 560 mm).

TECHNICAL DATA	WD-6 DUPLUS
Wash pump (kW)	0.9
Pump, recirculated rinse (kW)	0.58
Pump, final rinse (kW)	0.58
Booster heater (kW)	9
Tank heater (kW)	5.4
Tank volume, chemical wash tank (liter)	45
Tank volume, recirculated rinse (liter)	5.5
Weight, machine in operation (kg)	185
Enclosure class (IP)	45

CAPACITY AND OPERATING DATA	WD-6 DUPLUS
Total washing time P1 (min) *	1.2
Total washing time P2 (min) *	1.8
Total washing time P3 (min) *	3.3
Max. capacity, baskets/hour (no.)	50
Water consumption rinsing/programme (liter) **	1.0 - 1.5
Energy consumption (% of connected power)	30 - 50%
Sound level (dB(A))***	63

* Factory setting. The washing time can be adjusted.

** In combination with WD-PRM6 the water consumption can be lowered further.

*** Measured 1 metre from the side of the machine.

CONNECTION, MACHINE	WD-6 DUPLUS
Total connected power (kW)	9.9
Main fuse 400 3N- (A) *	16
Max. connection area 400-415V 3N- (L1-L3,N,PE) Cu (mm2) **	2.5

* Other voltage on request.

** Cable 3 m H07RN-F is included.

WATER, DRAIN AND VENTILATION CONNECTIONS	WD-6 DUPLUS
Water quality, hardness (°dH)	2 - 7
Water connection 5-65°C (external thread)*	R ½"
Drain connection, PP pipe (ø mm.)	50
Water capacity, min/max pressure (kPa)	20
Water capacity, flow (litres/min)	5
Floor drain, capacity (litres/sec)	3
Heat load to the room (total, sensible, latent) (kW)	1.7 / 1.2 / 0.5
For machines with the option ECO-FLOW: heat load to the room (total, sensible, latent) (kW)	0.9 / 0.6 / 0.3

* When using cold water <55°C the filling time is longer.

SIZE AND WEIGHT FOR TRANSPORTATION	WD-6 DUPLUS
Size, LxWxH (mm.)*	765x710x1560
Weight (kg)*	140

* Packaging included

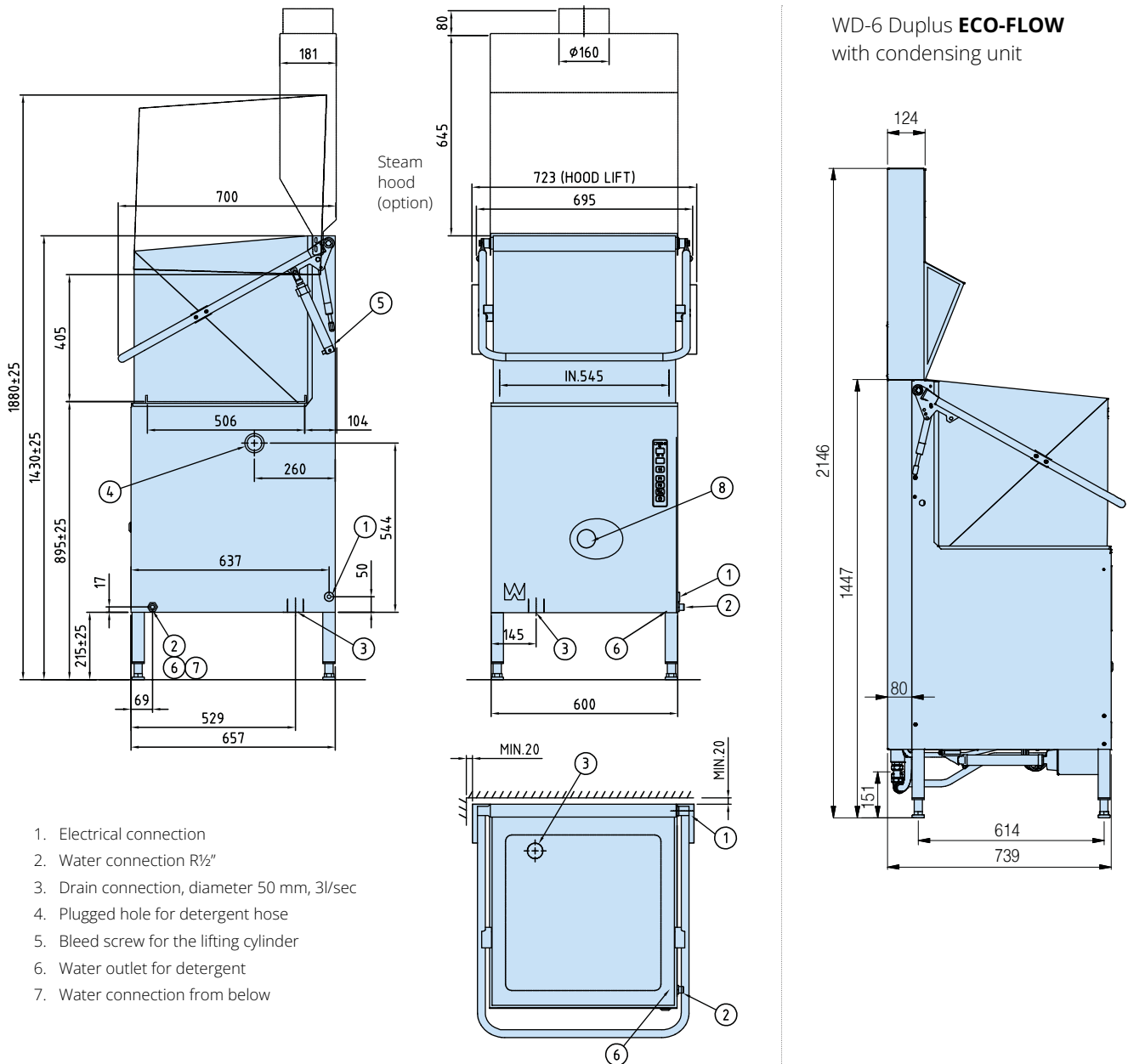

We reserve the right to change technical data.



WD-7

HOOD TYPE DISHWASHER

FEATURES

- Unique and flexible washing system. The machines water pressure can be reset quickly and easily between normal and heavily soiled settings
- Robust and reliable design in stainless steel with components that guarantee a durable and reliable operation for many years
- Thanks to the adjustable water pressure you can easily switch between normal and heavily soiled loads.
- The machine has an energy saving heat and sound insulating double-skinned hood
- A good working environment with the unique hood concept
- High levels of hygiene with an automatic cleaning programme and guaranteed rinse temperature by thermal stop system
- Self-drained wash pump
- Large deep tank to protect against foaming
- Easy servicing - the machine is serviced from the front
- Hygiene control – control system with integrated HACCP
- Excellent wash results – with selfdraining washing arms
- Powerful washing pressure with anti-blocking nozzles
- Individual adjustable wash- and rinse times as well as temperatures for each programme
- Inbuilt dosing pump for fine dosage of rinse aid
- Automatic cleaning program



OPTIONS

- Automatic hood
- Autostart for automatic hood
- 230V/1/50Hz
- 230V/3/50Hz
- Marine version
- Detergent pump for liquid detergent
- Panel on left side
- Lockable cabinet for chemicals (not in comb. with break tank or panel on left side)
- Booster heater for cold water connection
- Drain pump
- Separate filling of tank
- Break tank with booster pump (to be used when no external resuction protection is mounted)
- Booster pump connected with WD-PRM7 equipped with automatic hood (In combination with break tank)
- ECO-FLOW condensing unit with heat recovery by the exhausted steam. (cold water connection is required)
- Heat exchanger with heat recovery by the drain water. Not in combination with PRM. (cold water connection is required)
- WEB Tool - For external HACCP documentation

EXTRA EQUIPMENT

- Connection pipe with non-return valve and vacuum valve
- Steam hood with suction connection
- Shelf for chemical storage
- Sideboard (560 x 560 mm)
- Rack for 8 pcs baking plates
- Special rack for containers

TECHNICAL DATA	WD-7
Wash pump (kW)	1.1
Booster heater (kW)	9/12*
Tank heater (kW)	1.8
Tank volume (litres)	50
Weight, machine in operation (kg)	170
Enclosure class (IP)	45

* 12 kW booster heater is optional.

CAPACITY AND OPERATING DATA	WD-7
Total washing time P1 (min)	1.2**
Total washing time P2 (min)	1.7**
Total washing time P3 (min)	3.2**
Max. capacity, baskets/hour (no.)	50
Water consumption rinsing/programme (litres)	2.5-4***
Energy consumption (% of connected power)	70-90%
Sound level (dB(A))*	62/60

* Measured 1 metre from the side of the machine.

** Factory setting. The washing time can be adjusted.

*** The water consumption depends on local conditions. An exact adjustment is made during installation.

CONNECTION, MACHINE	WD-7
Total connected power (kW)	10.1/13.1*
Main fuse 400V 3N~ (A) **	16/25*
Max. connection area 400-415V 3N~ (L1-L3,N,PE) Cu (mm2) ***	2.5

* With 12 kW booster heater (optional).

** Other voltage on request.

*** Cable 3 m H07RN-F is included.

WATER, DRAIN AND VENTILATION CONNECTIONS	WD-7
Water quality, hardness (°dH)	2 - 7
Water connection 5-65°C (external thread)*	R ½"
Drain connection, PP pipe (ø mm.)	50
Water capacity, min/max pressure (kPa)	180**
Water capacity, flow (litres/min)	18
Water capacity hood lift, pressure (kPa)	300**
Floor drain, capacity (litres/sec)	3
Heat load to the room (total, sensible, latent) (kW)	2.3 / 1.7 / 0.6
For machines with the option ECO-FLOW: heat load to the room (total, sensible, latent) (kW)	1.2 / 0.9 / 0.3

- * If colder water than 55°C a 12 kW booster heater is recommended.
- ** If pressure/flow is lower the machine should be equipped with a break tank.

SIZE AND WEIGHT FOR TRANSPORTATION	WD-7
Size, LxWxH (mm.) *	765x805x1650
Weight (kg) *	125

* Packaging included

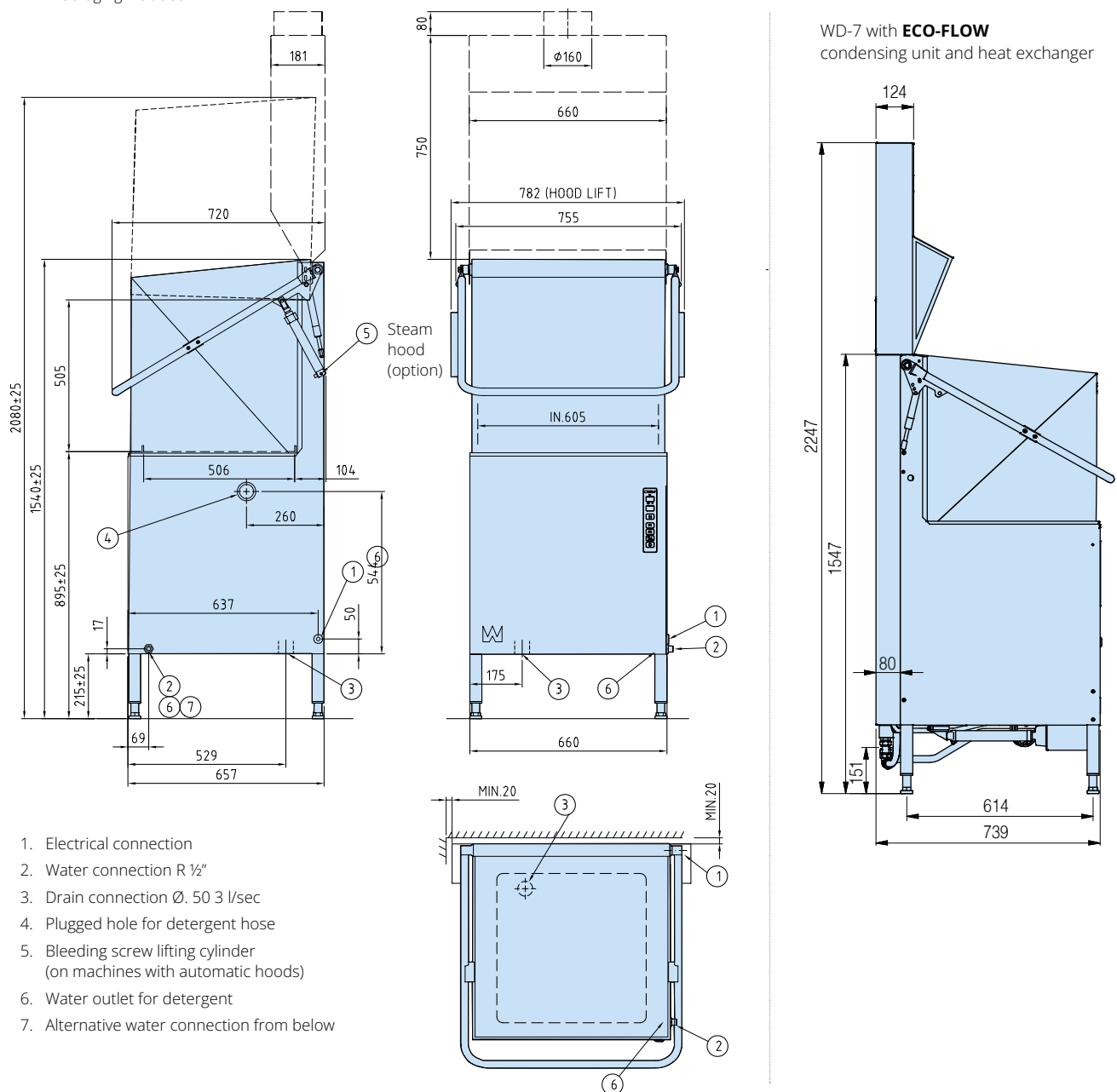

We reserve the right to change technical data.

WD-7 DUPLUS

HOOD TYPE DISHWASHER

FEATURES

- Double final rinse with DUPLUS technology
– Improved rinsing results using less fresh water.
- High efficiency with low operating costs
– DUPLUS technology reduces the consumption of fresh water, chemicals and electricity.
- Particularly large cost savings – if osmosis water has to be used.
- Unique and flexible washing system. The machines water pressure can be reset quickly and easily between normal and heavily soiled settings.
- Robust and reliable design in stainless steel with components that guarantee a durable and reliable operation for many years.
- The machine has an energy saving heat and sound insulating double-skinned hood.
- A good working environment with the unique hood concept.
- High levels of hygiene with an automatic cleaning programme and guaranteed rinse temperature by thermal stop system.
- Self-drained wash pump.
- Large deep tank to protect against foaming.
- Easy servicing - the machine is serviced from the front.
- Hygiene control – control system with integrated HACCP.
- Excellent wash results – with selfdraining washing arms.
- Powerful washing pressure with anti-blocking nozzles.
- Individual adjustable wash- and rinse times as well as temperatures for each programme.
- Inbuilt dosing pump for fine dosage of rinse aid.
- Break tank with booster pump.
- Automatic cleaning program.



OPTIONS

- Automatic hood.
- Autostart for automatic hood.
- 230V/3/50Hz
- Marine version.
- Detergent pump for liquid detergent.
- Panel on left side.
- Drain pump.
- Double water connection hot/cold.
- Booster pump connected with WD-PRM7 equipped with automatic hood (In combination with break tank).
- ECO-FLOW condensing unit with heat recovery by the exhausted steam (cold water connection is required).
- WEB Tool - For external HACCP documentation.

EXTRA EQUIPMENT

- Steam hood with suction connection.
- Shelf for chemical storage.
- Sideboard (560 x 560 mm).

TECHNICAL DATA	WD-7 DUPLUS
Wash pump (kW)	1.1
Pump, recirculated rinse (kW)	0.67
Pump, final rinse (kW)	0.67
Booster heater (kW)	9
Tank heater (kW)	5.4
Tank volume, chemical wash tank (liter)	45
Tank volume, recirculated rinse (liter)	5.5
Weight, machine in operation (kg)	195
Enclosure class (IP)	45

CAPACITY AND OPERATING DATA	WD-7 DUPLUS
Total washing time P1 (min) *	1.2
Total washing time P2 (min) *	1.8
Total washing time P3 (min) *	3.3
Max. capacity, baskets/hour (no.)	50
Water consumption rinsing/programme (liter) **	1.0 - 1.5
Energy consumption (% of connected power)	30 - 50%
Sound level (dB(A))***	63

* Factory setting. The washing time can be adjusted.

** In combination with WD-PRM7 the water consumption can be lowered further.

*** Measured 1 metre from the side of the machine.

CONNECTION, MACHINE	WD-7 DUPLUS
Total connected power (kW)	10.1
Main fuse 400 3N~ (A) *	16
Max. connection area 400V 3N~ (L1-L3,N,PE) Cu (mm ²) **	2.5

* Other voltage on request.

** Cable 3 m H07RN-F is included.

WATER, DRAIN AND VENTILATION CONNECTIONS	WD-7 DUPLUS
Water quality, hardness (°dH)	2 - 7
Water connection 5-65°C (external thread)*	R ½"
Drain connection, PP pipe (ø mm.)	50
Water capacity, pressure (kPa)	20
Water capacity, flow (litres/min)	5
Floor drain, capacity (litres/sec)	3
Heat load to the room (total, sensible, latent) (kW)	1.7 / 1.2 / 0.5
For machines with the option ECO-FLOW: heat load to the room (total, sensible, latent) (kW)	0.9 / 0.6 / 0.3

* When using cold water <55°C the filling time is longer.

SIZE AND WEIGHT FOR TRANSPORTATION	WD-7 DUPLUS
Size, LxWxH (mm.)*	765x805x1650
Weight (kg)*	160

* Packaging included

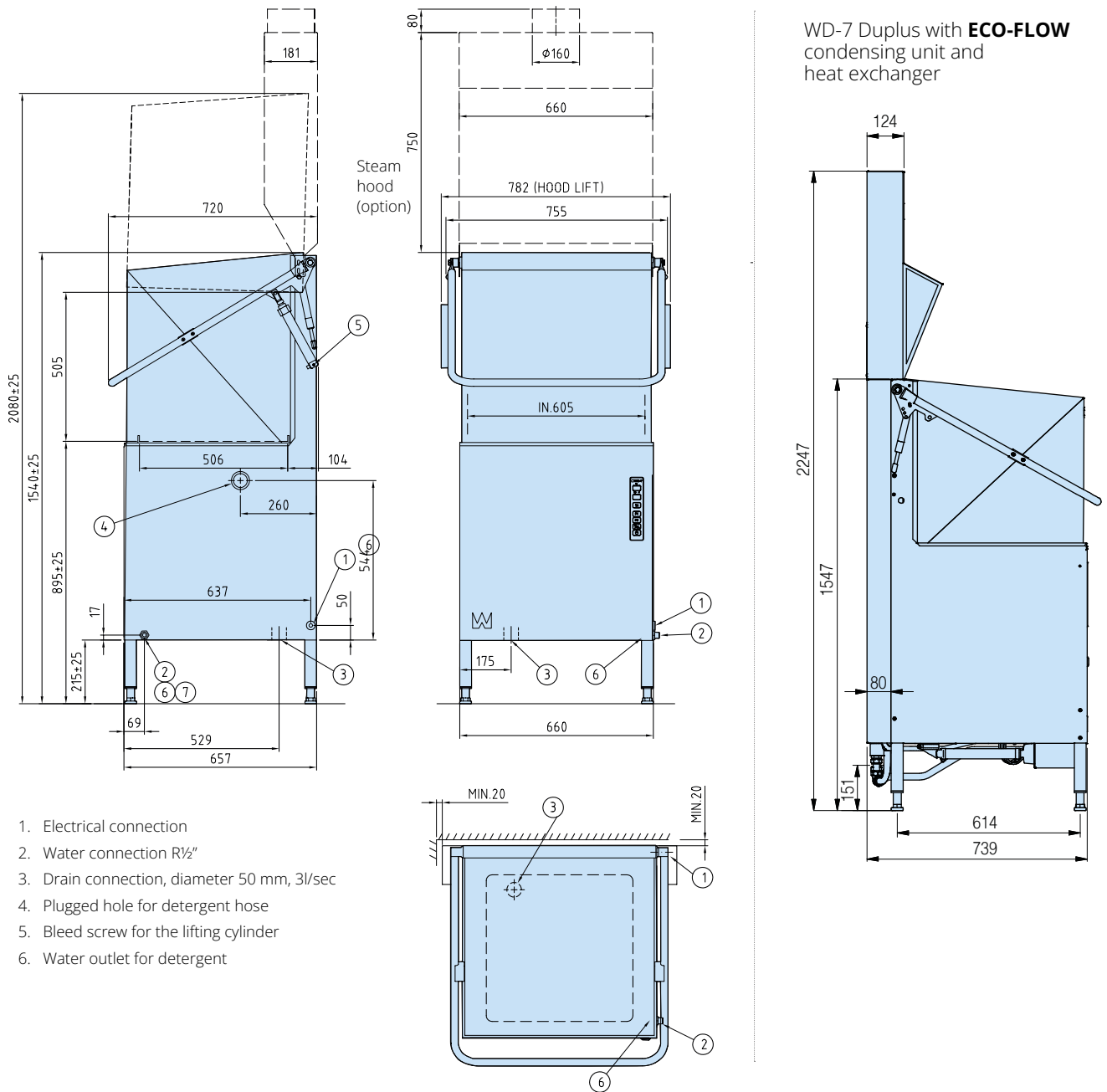

We reserve the right to change technical data.

HOOD TYPE DISHWASHER

FEATURES

- Unique and flexible washing system. The machines water pressure can be reset quickly and easily between normal and heavily soiled settings
- Robust and reliable design in stainless steel with components that guarantee a durable and reliable operation for many years
- The machine has an energy saving heat and sound insulating double-skinned hood
- A good working environment with the unique hood concept
- High levels of hygiene with an automatic cleaning programme and guaranteed rinse temperature by thermal stop system
- Self-drained wash pump
- Large deep tank to protect against foaming
- Easy servicing - the machine is serviced from the front
- Hygiene control – control system with integrated HACCP
- Excellent wash results – with selfdraining washing arms
- Powerful washing pressure with anti-blocking nozzles
- Individual adjustable wash- and rinse times as well as temperatures for each programme
- Inbuilt dosing pump for fine dosage of rinse aid
- Automatic cleaning program



OPTIONS

- Automatic hood
- Autostart for automatic hood (not in combination with foldable shelf)
- 230V/3/50Hz
- Detergent pump for liquid detergent
- Booster heater for cold water connection
- Foldable shelf
- Booster pump connected with WD-PRM7 equipped with automatic hood (In combination with break tank)
- ECO-FLOW condensing unit with heat recovery (cold water connection is required)
- Drain pump
- Separate filling of tank
- Break tank with booster pump (to be used when no external resuction protection is mounted)
- WEB Tool - For external HACCP documentation

EXTRA EQUIPMENT

- Shelf for chemical storage
- Sideboard (560 x 560 mm)
- Rack for 8 pcs baking plates
- Special rack for containers

TECHNICAL DATA	WD-8
Wash pump (kW)	1.5
Booster heater (kW)	9/12*
Tank heater (kW)	1.8
Booster pump (kW)**	0.6**
Drain pump (kW)**	0.04**
Tank volume (litres)	50
Weight, machine in operation (kg)	170
Enclosure class (IP)	45

- * 12 kW booster heater is optional.
 ** Optional.

CAPACITY AND OPERATING DATA	WD-8
Total washing time P1 (min)	1.2**
Total washing time P2 (min)	1.7**
Total washing time P3 (min)	3.2**
Max. capacity, baskets/hour (no.)	50
Water consumption rinsing/programme (litres)	2.5-4***
Energy consumption (% of connected power)	70-90%
Sound level (dB(A))*	62/60

- * Measured 1 metre from the side of the machine.
 ** Factory setting. The washing time can be adjusted.
 *** The water consumption depends on local conditions. An exact adjustment is made during installation.

CONNECTION, MACHINE	WD-8
Total connected power (kW)	10.5/13.5*
Main fuse 400V 3N~ (A) **	16/25*
Max. connection area 400-415V 3N~ (L1-L3,N,PE) Cu (mm2) ***	2.5

- * With 12 kW booster heater (optional).
 ** Other voltage on request.
 *** Cable 3 m H07RN-F is included.

WATER, DRAIN AND VENTILATION CONNECTIONS	WD-8
Water quality, hardness (°dH)	2 - 7
Water connection 5-65°C (external thread)*	R 1/2"
Drain connection, PP pipe (ø mm.)	50
Water capacity, min/max pressure (kPa)	180**
Water capacity, flow (litres/min)	18
Water capacity hood lift, pressure (kPa)	300**
Floor drain, capacity (litres/sec)	3
Heat load to the room (total, sensible, latent) (kW)	2.3 / 1.7 / 0.6
For machines with the option ECO-FLOW: heat load to the room (total, sensible, latent) (kW)	1.2 / 0.9 / 0.3

* If colder water than 55°C a 12 kW booster heater is recommended.

** If pressure/flow is lower the machine should be equipped with a break tank.

SIZE AND WEIGHT FOR TRANSPORTATION	WD-8
Size, LxWxH (mm.) *	765x880x1650
Weight (kg) *	135

* Packaging included

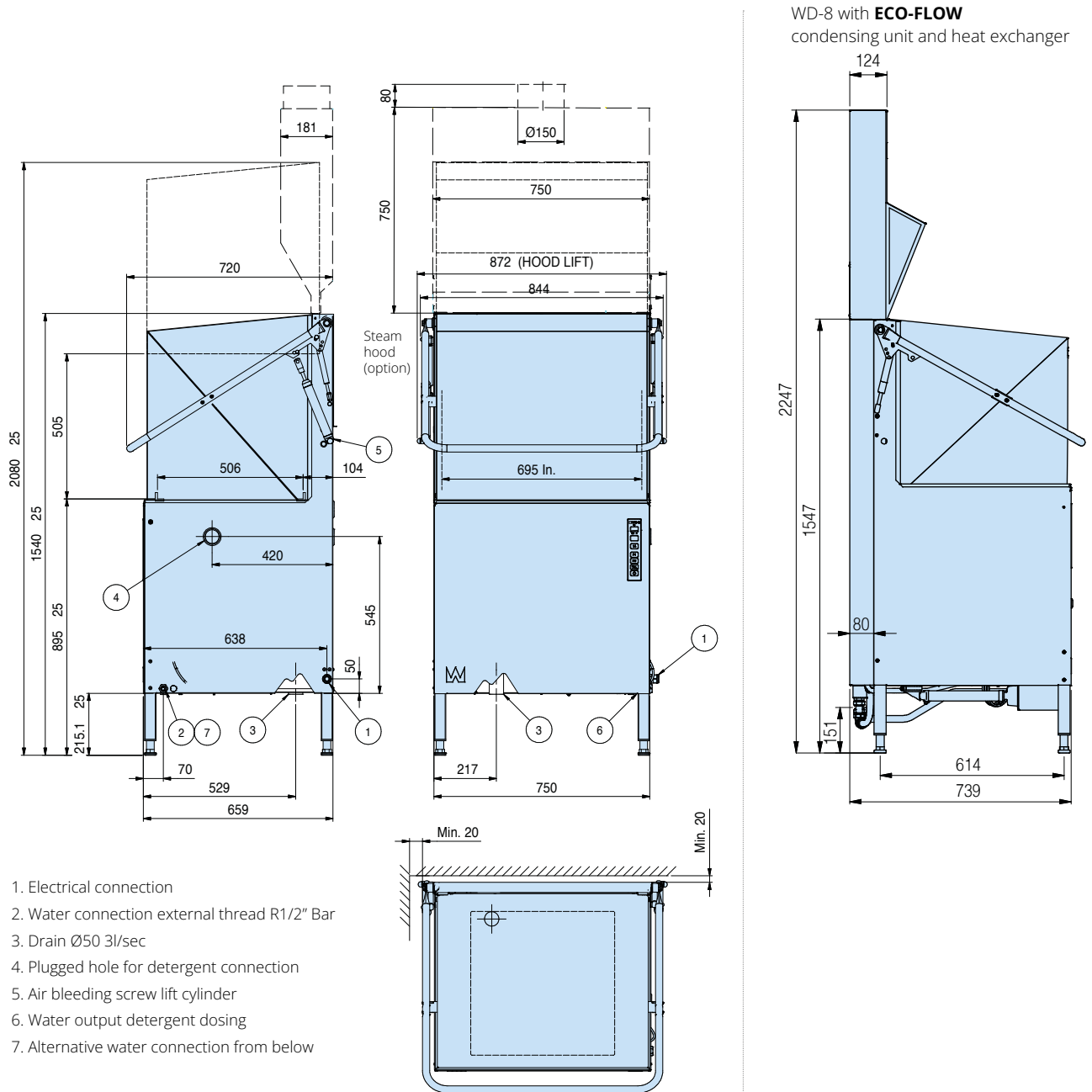

We reserve the right to change technical data.



WD-PRM 6/7

PRE-RINSE MACHINE

FEATURES

- The automatic Pre rinse machine replace the manual pre rinsing
- Hot recycled detergent water is used both from above and underneath the ware leading to a better washing result
- Great water savings is achieved because the pre rinse machine only use water from the dishwasher that normally goes to the drain
- Saves working time - possible to accumulate dish ware which leads to large savings
- The total contact time is extended and the wash ware is almost clean before they enter the dishwasher. That means better capacity for the dishwasher because shorter programs can be used
- The working environment is improved by replacing the repetitive manual pre-rinsing movements

- Robust and reliable design in stainless steel with components that guarantee a durable and reliable operation for many years
- The machine has an energy saving heat and sound insulating double-skinned hood.
- A good working environment with the unique hood concept
- Self-drained wash pump
- Large deep tank to protect against foaming
- Wash pump intake with strainer

- Easy servicing - the machine is serviced from the front
- Powerful washing pressure with anti-blocking nozzles



OPTIONS

- Automatic hood
- Autostart for automatic hood
- 230V/1/50Hz
- 230V/3/50Hz
- Marine version
- Panel on left side
- Booster pump

EXTRA EQUIPMENT

- Sideboard (560 x 560 mm)
- Connection plate with or without splash guard between PRM

TECHNICAL DATA	WD-PRM6	WD-PRM7
Article number	204-006	204-007
Wash pump (kW)	0.9	0.9
Tank volume (litres)	45	45
Weight, machine in operation (kg)	130	150
Degree of protection (IP)	45	45

CAPACITY AND OPERATION DATA	WD-PRM6	WD-PRM7
Total time pre-rinse (sec)	30/45/60	30/45/60
Capacity, max (baskets/h)**	120	120
Sound level* (dB(A))	64	64

* Measured 1 metre from the machine
 ** At 30 sec pre-rinse time

CONNECTION, MACHINE	WD-PRM6	WD-PRM7
Total connected power (kW)	0.9	0.9
Main fuse 400V 3N~(A)*	10	10
Max.conn.area 400V 3N~ (L1-L3,N,PE) Cu (mm ²)**	2.5	2.5

* Other voltages on request
 ** Cabel 2m H07RN-F included

CONNECTION WATER, DRAIN AND VENTILATION	WD-PRM6	WD-PRM7
Drain connection, PP pipe (ø mm)	50	50
Water capacity cold water hood lift, pressure (kPa)*	180	300
Water capacity cold water hood lift, flow (l/min)*	2	2
Floor drain, capacity (litres/sec)	3	3
Heat load to the room (total, sensible, latent) (kW)	0.3 / 0.2 / 0.1	0.3 / 0.2 / 0.1

* Option. If pressure / flow is lower the machine should be equipped with a booster pump.

SIZE AND WEIGHT FOR TRANSPORTATION	WD-PRM6	WD-PRM7
Size * LxWxH (mm)	765x710x1560	765x805x1650
Weight * (kg)	100	105

* Packaging included

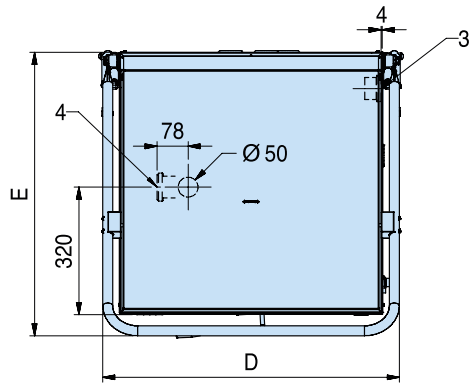
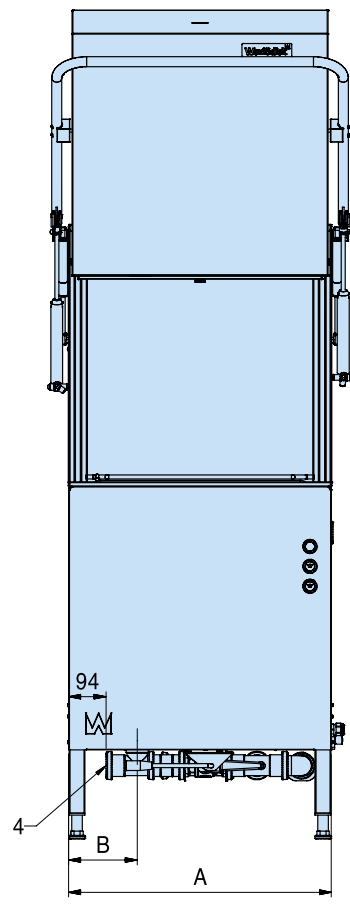
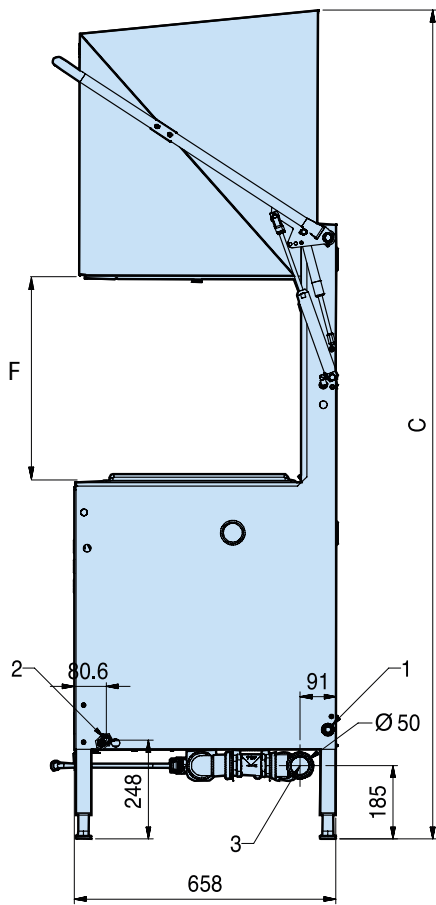

1. Electrical connection
2. Cold water connection R1/2" - hood lift
3. Water connection Ø50mm int. from dishwasher
4. Drain connection Ø50mm int.

DIM MM	WD-PRM6	WD-PRM7
A	600	660
B	142	172
C	1900	2084
D	685	745
E	707	713
F	405	505

We reserve the right to change technical data.



WD-6C

HOOD TYPE DISHWASHER

FEATURES

- Robust and reliable design in stainless steel with components that guarantee a durable and reliable operation for many years
- The machine has an energy saving heat and sound insulating double-skinned hood.
- A good working environment with the unique hood concept
- Self-drained wash pump
- Large deep tank to protect against foaming
- Wash pump intake with strainer
- Easy servicing - the machine is serviced from the front
- Excellent wash results – with selfdraining washing arms
- Powerful washing pressure with anti-blocking nozzles
- Dosing pump for fine dosage of rinse aid

OPTIONS

- 230V/3/50Hz
- Detergent dispenser for liquid detergent
- Drain pump

EXTRA EQUIPMENT

- Steam hood with suction connection
- Shelf for chemical storage
- Sideboard (560 x 560 mm)



TECHNICAL DATA	WD-6C
Wash pump (kW)	0.9
Booster heater (kW)	9
Heater tank (kW)	1.8
Tank volume (litres)	50
Weight, machine in operation (kg)	160
Degree of protection (IP)	45

CAPACITY AND OPERATION DATA	WD-6C
Total time/wash program 1 (min)	1.5
Capacity, max (baskets/h)	35
Water consumption rinse/program (litres)	4
Energy consumption (kWh of connected power)	70-90%
Sound level* (dB(A))	61

* Measured 1 metre from the machine.

CONNECTION, MACHINE	WD-6C
Total connected power (kW)	9.9
Main fuse 400V 3N~ (A)*	16
Max connection area 400V 3N~(L1-L3, N, PE) Cu (mm2)**	2.5

* Other voltages on request.

** Cabel 2.5m H07RN-F included.

CONNECTION WATER, DRAIN AND VENTILATION	WD-6C
Water quality, hardness (°dH)	2-7
Hot water connection 50-65°C (external thread)	R 1/2"
Drain connection, PP pipe (ø mm)	50
Water capacity, pressure (kPa)	180**
Water capacity, flow (litres/min)	18
Floor drain, capacity (litres/sec).	3
Heat load to the room (total, sensible, latent) (kW)	2.3 / 1.7 / 0.6

** If pressure / flow is lower the machine should be equipped with a break tank.

SIZE AND WEIGHT FOR TRANSPORTATION	WD-6C
Size LxWxH (mm) *	765x710x1560
Weight (kg) *	115

* Packaging included.

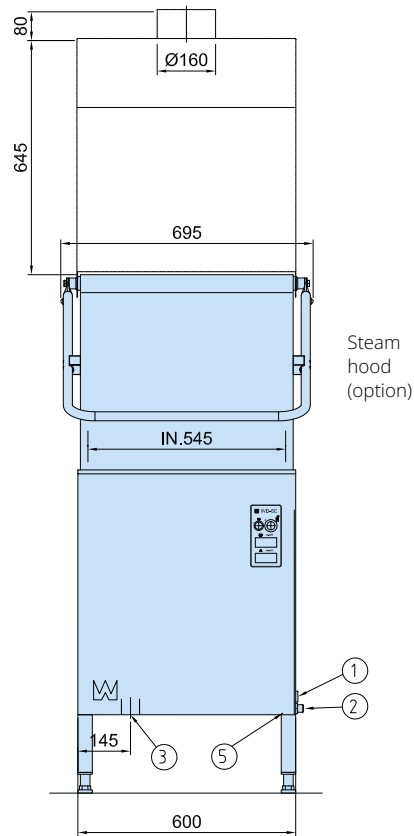
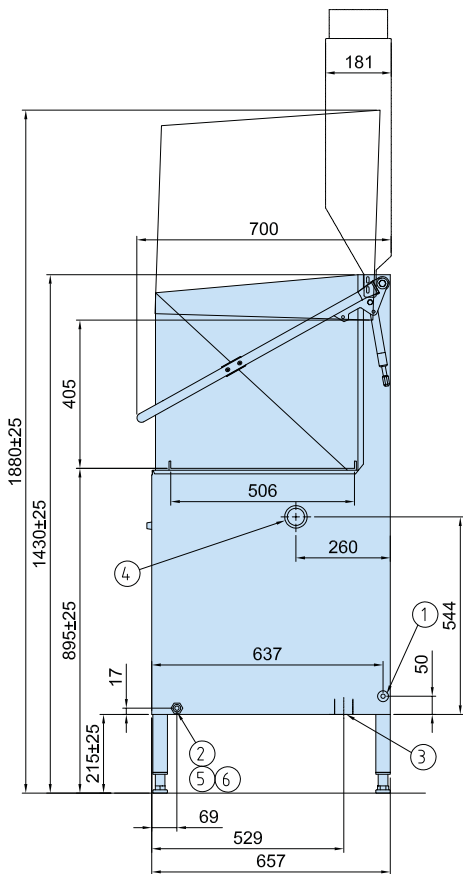

1. Electrical connection
2. Water connection R1/2"
3. Drain connection, diameter 50 mm, 3l/sec
4. Plugged hole for detergent hose
5. Water outlet for detergent
6. Alternative water connection from below

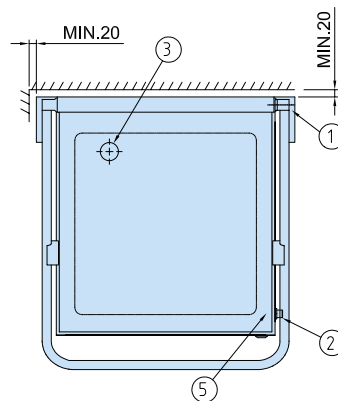

We reserve the right to change technical data.

По вопросам продаж и поддержки обращайтесь:

Алматы (727)345-47-04
Ангарск (3955)60-70-56
Архангельск (8182)63-90-72
Астрахань (8512)99-46-04
Барнаул (3852)73-04-60
Белгород (4722)40-23-64
Благовещенск (4162)22-76-07
Брянск (4832)59-03-52
Владивосток (423)249-28-31
Владикавказ (8672)28-90-48
Владимир (4922)49-43-18
Волгоград (844)278-03-48
Вологда (8172)26-41-59
Воронеж (473)204-51-73
Екатеринбург (343)384-55-89

Иваново (4932)77-34-06
Ижевск (3412)26-03-58
Иркутск (395)279-98-46
Казань (843)206-01-48
Калининград (4012)72-03-81
Калуга (4842)92-23-67
Кемерово (3842)65-04-62
Киров (8332)68-02-04
Коломна (4966)23-41-49
Кострома (4942)77-07-48
Краснодар (861)203-40-90
Красноярск (391)204-63-61
Курск (4712)77-13-04
Курган (3522)50-90-47
Липецк (4742)52-20-81

Магнитогорск (3519)55-03-13
Москва (495)268-04-70
Мурманск (8152)59-64-93
Набережные Челны (8552)20-53-41
Нижний Новгород (831)429-08-12
Новокузнецк (3843)20-46-81
Ноябрьск (3496)41-32-12
Новосибирск (383)227-86-73
Омск (3812)21-46-40
Орел (4862)44-53-42
Оренбург (3532)37-68-04
Пенза (8412)22-31-16
Петрозаводск (8142)55-98-37
Псков (8112)59-10-37
Пермь (342)205-81-47

Ростов-на-Дону (863)308-18-15
Рязань (4912)46-61-64
Самара (846)206-03-16
Санкт-Петербург (812)309-46-40
Саратов (845)249-38-78
Севастополь (8692)22-31-93
Саранск (8342)22-96-24
Симферополь (3652)67-13-56
Смоленск (4812)29-41-54
Сочи (862)225-72-31
Ставрополь (8652)20-65-13
Сургут (3462)77-98-35
Сыктывкар (8212)25-95-17
Тамбов (4752)50-40-97
Тверь (4822)63-31-35

Тольятти (8482)63-91-07
Томск (3822)98-41-53
Тула (4872)33-79-87
Тюмень (3452)66-21-18
Ульяновск (8422)24-23-59
Улан-Удэ (3012)59-97-51
Уфа (347)229-48-12
Хабаровск (4212)92-98-04
Чебоксары (8352)28-53-07
Челябинск (351)202-03-61
Череповец (8202)49-02-64
Чита (3022)38-34-83
Якутск (4112)23-90-97
Ярославль (4852)69-52-93

Россия +7(495)268-04-70

Казахстан +7(727)345-47-04

Беларусь +(375)257-127-884

Узбекистан +998(71)205-18-59

Киргизия +996(312)96-26-47

эл.почта: wkd@nt-rt.ru || сайт: <https://wexiodisk.nt-rt.ru/>